



**COMMERCIAL OPERATIONS & MAINTENANCE MANUAL
FOR THE NIBBLER® WASTEWATER TREATMENT SYSTEM**

SERVING

Project Name
City, State

Prepared By:
AQUA TEST INC
P.O. Box 1116
Black Diamond, WA 98010

(800) 221-3159
(425) 413-9431 Fax

TABLE OF CONTENTS

| <u>ITEM</u> | <u>SECTION</u> |
|---------------------------------|----------------|
| Monitoring Schedule | 1 |
| • Monitoring Checklist | |
| Management Guide | 2 |
| • Introduction | |
| • Operation | |
| • Troubleshooting | |
| • Dissolved Oxygen (DO) | |
| • Control Panels | |
| • Message to the Owner/Operator | |
| Electrical Information | 3 |
| Control Panel Specifications | 4 |
| • Panel Information | |
| • Float Information | |
| • Timer Setting Instructions | |
| Blower Specifications | 5 |
| Pump Specifications | 6 |
| • Pump Dosing Information | |

SECTION 1

MONITORING SCHEDULE

MONITORING SCHEDULE

Listed below is the recommended inspection and sampling schedule for a NIBBLER® system. The influent sample should be collected from the clear zone of the surge tank, and the effluent sample should be collected from the inlet of the pump tank or basin.

FIRST SIX MONTHS

- a. Start up month
- b. 1 month after start up-begin sampling
- c. 2 months after start up-sample collected
- d. 3 months after start up-sample collected
- e. 4 months after start up-sample collected
- f. 5 months after start up-sample collected
- g. 6 months after start up-sample collected

QUARTERLY

- h. 9 months after start up-sample collected
- i. 12 months after startup-sample collected
- j. **Repeat quarterly inspections**

There are exceptions to the monitoring frequencies listed herein. For systems designed at less than or equal to 4.86 lbs BOD₅ per day the inspection will occur on a semi annual basis

Wastewater Sampling: The NIBBLER® wastewater treatment process is performance based system which requires sampling to verify performance standards. A sample shall consist of the following analytical parameters: BOD₅, TSS, Oil and Grease, pH, Temperature, and Dissolved Oxygen. All systems are to be sampled for effluent quality on a quarterly basis unless a revocable letter of authorization from the manufacturer grants a reduced sampling frequency. Reduced sampling frequencies will be granted for the following conditions:

- If the system is operating at 50 percent of the design organic load capacity.
- If the system is operating at 75percent of the maximum discharge limit and at least two consecutive sample are less than or equal to 112 mg/L BOD₅ , the GPD remains within 10% of the previous two inspections, and the pH and DO remain constant.
- Effluent dissolved oxygen concentration greater than 3.5 mg/L and system toxicity is not observed

During each scheduled inspection, the Monitoring Checklist (next page) should be appropriately filled out. Then a copy of the checklist should be mailed or faxed to:

Address:

AQUA TEST INC
P.O. Box 1116
Black Diamond, WA 98010

Fax Number:

(425) 413-9431

Note: Monitoring schedule may vary. The schedule should follow any health department requirements.

MONITORING CHECKLIST

Site Identification

City, State

MAX. INFLUENT DESIGN RATE: GPD XXXX / BOD₅ XXX mg/L

MAX. EFFLUENT LEVELS: CBOD₅ 120 mg/L, TSS 80 mg/L & O&G 20 mg/L

DATE _____ TIME _____ INSPECTION ID _____

DATE LAST CHECKED _____ DAYS THIS PERIOD _____ INSPECTED BY _____

Surge Tank Calibration:

Tank Size: _____ Gallons No. of Tanks: _____ Capacity: flood / working Gal. Per Inch (GPI): _____

Pump Drawdown Time: _____ Minutes Drawdown: _____ Inches Convert to decimal _____

_____ Inches x _____ GPI x _____ No. of Tanks = _____ Gallons ÷ _____ Minutes = _____ GPM

XXXX GPD/ _____ No of Cycles = _____ GPC (48, 72, or 96 to get Gal. Per Cycle. Min gal should be 25 and max gal should be 100)

Gal. Per Cycle (GPC): _____ at _____ Cycles Per Day (CPD) 1440 / _____ CPD = _____ Min. per cycle

_____ GPC/ _____ GPM = _____ On time per cycle _____ Min per cycle - _____

On Time = _____ Off Time

Nibbler Feed Pump Settings:

Run time: _____ Sec / Min Off time: _____ Min / Hr

On time set at: _____ mode Dial set at: _____

Off time set at: _____ mode Dial set at: _____

Set for _____ pump cycles per day & _____ GPD

HOURLY METER (_____ GPM):

ACCUM. HRS _____ - LAST READING _____ = HRS THIS PERIOD _____

_____ HRS x 60 min x _____ GPM / _____ Days in period = **GPD** _____

CYCLE COUNTER @ SURGE TANK: (_____ GPC)

ACCUM. CYCLES _____ - LAST READING _____ = CYCLES THIS PERIOD _____

$\frac{\text{GPC} \times \text{CYCLES}}{\text{DAYS THIS PERIOD}} = \text{GPD}$

OFF COUNTER:

ACCUM. COUNTS _____

PREVIOUS _____

COUNTS _____

NIBBLER FEED ORIFICES: CLEAN CLOGGED / WERE CLEANED

VERIFY NIBBLER SETTINGS: CORRECT INCORRECT

CHECK ALARM FLOTS 50 / 90 LIGHTS & AUDIBLE OK YES / NO

| | BOD ₅ | TSS | O&G | pH | TEMP | DO |
|------------------------------|------------------|-------|-------|-------|-------|-------|
| SURGE TANK - NIB INFLUENT | _____ | _____ | _____ | _____ | _____ | _____ |
| CLARIFIER IN - NIB EFFLUENT: | _____ | _____ | _____ | _____ | _____ | _____ |

SLUDGE RETURN PUMP IN AUTO OPERATION (WEO311M 1/3 HP): YES / NO

MANUALLY RECIRCULATED SLUDGE: YES / NO APPROX. _____ GALS

VERIFY FEED SETTINGS: CORRECT INCORRECT

EXHAUST VENT: VISIBLE FOAM RESIDUE? YES _____ NO _____
IF 'YES' CHECK FOR CLOGGED MEDIA AND SLUDGE LEVELS IN TANK

ODORS NONE _____ SLIGHT _____ OBNOXIOUS _____

AIR INTAKE FILTER: CLEAN _____ NEEDED CLEANING/WAS CLEANED _____

| | | |
|--|--|-----------------------------------|
| AIR PUMPS IN NIBBLER: | | VELOCITY OF AIR PUMPS: |
| UNIT #X: WORKING _____ NOT WORKING _____ | | HIGH _____ LOW _____ NORMAL _____ |
| UNIT #X: WORKING _____ NOT WORKING _____ | | HIGH _____ LOW _____ NORMAL _____ |

| | | | |
|------------------------|-------|-------|-------|
| FOAMING ACTION: | HIGH | LOW | COLOR |
| UNIT #X: | _____ | _____ | _____ |
| UNIT #XX: | _____ | _____ | _____ |

| | | | |
|-----------------------------|---------------|--------------|-------|
| SLUDGE LEVELS: | ACCUM. SLUDGE | FLOATING MAT | COLOR |
| XXX GAL. GREASE TRAP | _____ " | _____ " | _____ |
| XXXX GAL. SURGE TANK | _____ " | _____ " | _____ |
| NIBBLER #X | _____ " | _____ " | _____ |
| NIBBLER #X | _____ " | _____ " | _____ |
| XXX GAL. 2 COMP. CLARIFIER: | | | |
| 1ST COMP. | _____ " | _____ " | _____ |
| 2ND COMP. | _____ " | _____ " | _____ |

CHECK BAFFLE IN CLARIFIER: CLEAN _____ CLOGGED / WAS CLEANED _____

SECTION 2

MANAGEMENT GUIDE

NIBBLER[®] High Strength Wastewater Pretreatment System

Operations & Maintenance

Facility Name & Location _____

Installed on: _____, _____ Pod system designed to treat _____ GPD with a maximum BOD₅ of _____ mg/L.

INTRODUCTION

The NIBBLER[®] is a secondary sewage treatment system designed specifically for use where high waste strength is a problem. Laboratory tests have proven that the NIBBLER[®] is capable of reducing waste strength to levels similar to typical household septic tank effluent before it is discharged into a drainfield, advanced treatment unit, or public sewer.

As a condition of the NIBBLER[®]'s approval as an alternative sewage treatment device, the owner of each facility employing a NIBBLER[®] must enter into a monitoring and maintenance agreement with an approved management entity*. (*An approved management entity is one acceptable to both manufacturer and the permit issuing agency.)

The management entity will perform regular inspections of the NIBBLER[®] system, which will include laboratory analyses of wastewater samples (before and after treatment) and physical inspections of the unit and the facility as required. It will perform or oversee all maintenance of the NIBBLER[®] system and will be responsible for keeping the manufacturer, the facility owner and the permit issuing agency fully informed as to the performance and maintenance of the system.

The purpose of this Operations and Maintenance Manual is to familiarize to its basic operation and to help them recognize potential problems at their onset. Those persons should not attempt to take the place of the management entity, but should work in close cooperation with it. More detailed information will be made available to approved management companies upon request.

SAFETY/PUBLIC HEALTH CONSIDERATIONS

Possible health hazards need to be taken into consideration when working with or maintaining any sewage treatment system, therefore it is recommended that appropriate sanitary precautions, including the use of disposable gloves, be practiced at all times when handling any type of wastewater.

Should the NIBBLER[®] fail, or if the NIBBLER[®] components are removed, for any reason, the tanks can serve as holding tanks and be pumped out as needed by a licensed pumper: the sludge disposed of by approved methods until such time as the NIBBLER[®] can be restored to full operation.

EQUIPMENT

Each NIBBLER[®] system is designed specifically for the individual site on which it is installed; therefore component parts may vary from system to system. Questions concerning component parts should be directed to the manufacturer.

Electrical panel circuit breakers should be clearly labeled, especially the circuit breakers for the regenerative blowers (fans) and each pump. Power to these components should not be interrupted. If power is interrupted to the blower, the blower may start-up backwards when the power is restored. Always check the blower, at the inlet to the blower, for proper operation when power is restored. The system should always be in the auto mode when you leave the site.

WHEN TO PUMP-OUT THE NIBBLER[®] TANK

It is important that the sludge level in the unit be checked at least four times annually (quarterly).

Using a device called a “Sludge Judge” a core sample can be collected from the unit, which will determine the actual depth of the sludge and scum layers. Other products are on the market for evaluating the sludge/scum level in a tank however; the “Sludge Judge” is a reliable tool. The sludge level should always be at least 12” below the bottom of the outlet baffle.

OPERATION

The NIBBLER[®] treatment system is an aerobic digester. It treats sewage and high strength biodegradable wastewater by utilizing a population of microorganisms, which are capable of digesting the waste. The only mechanical devices used in its operation are a blower fan which provides the oxygen required to support the aerobic microorganism population and pumps which transfer effluent to various components of the system. A control panel is required to control the system pumps and alarms.

Visual Observations:

Monitoring starts even before you step out of your vehicle. Visual observations can be the simplest, yet sometimes the most important, of any maintenance skills used. Some of the visual signs to look for include:

1. Checking the venting system for foaming.
 - a. A small amount of foaming may be a part of your system's normal operation. If foaming is excessive, there are steps which can be taken to reduce or eliminate the amount of foam discharged from the vent system.

b. It is not unusual for a system to foam at startup, especially if extra cleaning is going on in the facility. The owner/operator must be aware that high sudsing detergents are not recommended and can cause excessive foaming from the NIBBLER[®] vent.

c. If a systems food source is cut off (feed pump goes out or the business is closed) excess foam may be noticed in 24 to 48 hours. This will be followed by a major reduction in foam. If you get foaming In a system, which previously was not foaming, check the feed to the NIBBLER[®] system.

2. Checking for uneven vegetative growth or evidence of surfacing effluent on or around the tanks and drainfield area.
3. Observing the lids on the NIBBLER[®] tank for air leaks (bubbling).
4. Obvious tampering of the system. Are the locks, lids, and bolts as they were when you last left the system?

1st Task: Check flows

Before doing anything else, checking the Gallons Per Day (GPD) is always first. Record cycle counter and hour meter readings and perform the necessary calculations to determine the hydraulic loading of the system. From this information you will be able to tell if there have been excessive flows, possible equipment failure or tampering of timing devices. If you suspect a problem the liquid levels in the relevant tanks should be inspected before collecting a sample. Look for high or low water levels and/or evidence of high water levels. You may observe scum rings on the inside of the riser, which is an indicator of a high water level.

2nd Task: Collect samples

Before any work is performed that may influence misrepresent or invalidate the quality of the effluent, a sample should he collected.

3rd Task: Perform routine maintenance

These tasks will include, but are not limited to:

1. Inspecting outlet baffles & screens for clogging.
2. Checking scum/sludge levels in various tanks.
 - a. The NIBBLER[®] unit, under normal operating conditions will generally have three types of sludge present.

(1) As a system matures, the top of the tank and the media will develop a light brown growth. If this bio-growth appears to be impeding the flow or circulation in the tank it should be washed down as outlined in the

troubleshooting section, if the scum appears black there may be a problem, and the media may require a wash down.

(2) At the very bottom of the tank you will find sludge with the consistence of “crude oil”. This is the sludge you want to monitor for pumping the tank. This heavy sludge should never be any closer than 12” from the bottom of the outlet baffle.

(3) Above the heavy sludge at the bottom of the tank you will find a lighter “flocculent” type of sludge. This material will not be as dark in color as the heavy sludge and will appear to be suspended in your sludge profile. This material is very dynamic and the thickness of this layer will change dramatically between inspections. You may inspect one week and find 14” of “floc” and come back a week later and only find a couple of inches. It is acceptable for this material to come within 12” of the bottom of the outlet baffle, any carry over of this material will be settled out in the clarifier. This material eventually becomes the “crude oil” sludge.

b. Do not use the “Sludge Judge” to measure the scum layer in a grease trap. The scum layer should be checked using a bent rod. Push the rod through the scum layer, twist and pull up gently. You will feel the bottom of the scum layer and can estimate the thickness. The scum layer should not be any closer than 6” from the bottom of the outlet baffle.

c. The sludge layer in the clarifier should not exceed 12”. If the sludge level does exceed 12” use the clarifier sludge return pump to send the sludge back to the Grease Trap or Septic Tank.

d. The combined thickness of the sludge and scum blanket in any septic tank or grease trap should not exceed 1/2 of the tank volume or be within 12’ of the bottom of the outlet baffle.

3. Inspecting the airflow to the NIBBLER[®] unit.

a. The air intake to the blower in the fan house should be clean. Also the inlet to the blower should be checked for the proper direction of air flow.

b. Check the air tubes of each pod in the NIBBLER[®] tank. There should be equal turbulence in each pod.

4. Checking NIBBLER[®] feed orifices for clogging; If the splitter basin is utilized check the discharge tube rims to be sure they are free from debris and discharging equally.

5. Check sludge levels in media. Refer to the previous section.

When to clean the NIBBLER® unit:

1. Sludge levels indicate pumping is required (previous section).
2. NIBBLER® media is plugged.

How:

1) Shut off power to the fan.

2) Place the hose from the pump-out truck down through the media to the bottom of the tank and pump out the sludge. You will then need to use a hose with a pressure nozzle to wash down the media. This will remove the dead sloughing bio-growth. As the liquid level in the tank lowers, it is critical that you make certain that the liquid level does not fall below the bottom of the media pods before the media is completely washed, otherwise the pods may collapse from the weight of the biomass. Once the media has been completely cleaned it is important that the unit be filled back up with fresh water or treated sewage from a downstream component and the power restored.

The following picture shows what a properly operating NIBBLER® looks like. (4 & 6pod tanks will have a baffle wall, not shown.)

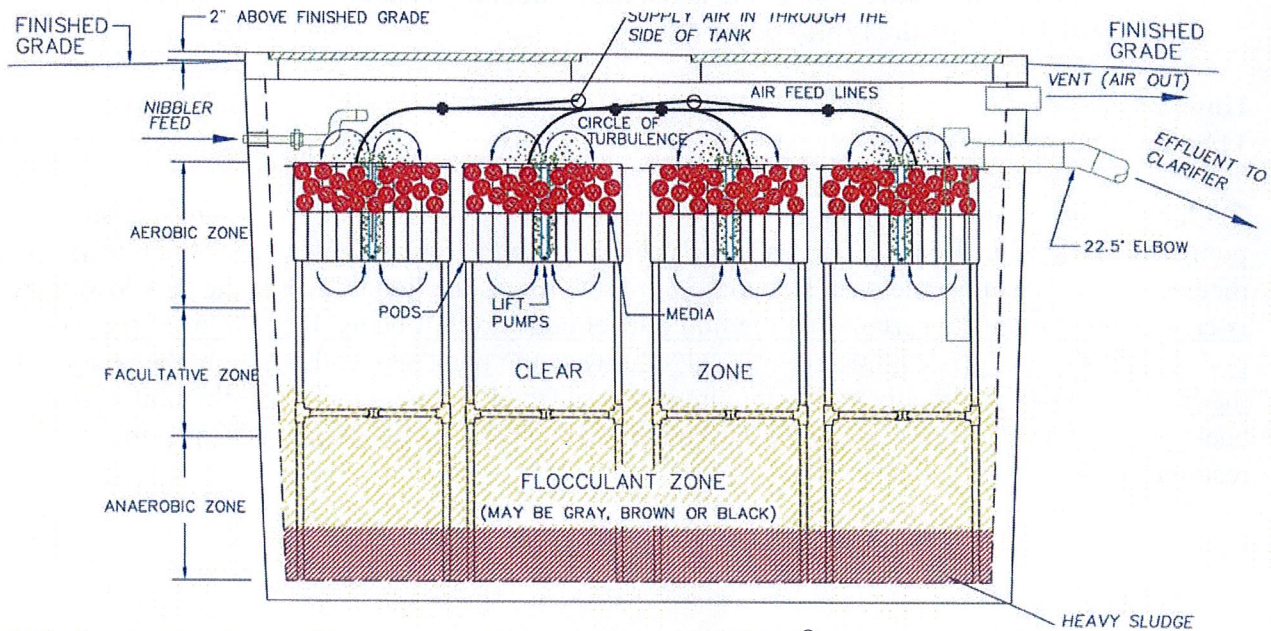

This is what is observed in a property operating NIBBLER®:

Vent Odor from vent will be mild and inoffensive. Little or no foam should be emitted from vent after one month of operation.

Foam A layer of foam (about 6" to 12" thick) may be present above the mixing liquid. Foam will either be white, grey-yellow or grey-brown in color. Foam coloration is an indication of whether or not the NIBBLER® is operating within its design capabilities.

- *White* Under loaded (receiving less waste strength than system was designed to handle). An under loaded system may have no foam.
- *Grey/Yellow* Overloaded (receiving more than design rate). Indicates a excessively high oil and grease loading
- *Grey/Brown* Normal (operating at or near design rate) Ideally. The foam will be an extremely light grey-brown in color.
- *Black* Any black specks in the foam or a black mat below the foam (on the liquid surface) are indications of biological kill-off

Turbulence Air flow should be sufficient to produce overlapping *circles of turbulence* on the mixing liquid surface.

If your NIBBLER® system does not appear as mentioned above, notify management immediately and see troubleshooting guide which follows

TROUBLESHOOTING

EXCESSIVE FOAMING

Indication: Foam extends to lid of unit or escapes through the exhaust vent.

Cause

Solution

Excessive use of soap products
or use of a high sudsing detergent

Change to low sudsing soap products.
Monitor amounts of soap/cleaning products used. Notify
management entity of any product changes.

Excess hydraulic loading

Notify management entity - Cycle counter should be
checked to determine if the volume of wastewater entering
the unit is within its design capabilities.

System biologically overloaded
(grey-yellow foam)

Notify management entity - If system has a surge
tank and pump, it may need to be adjusted to provide more
frequent, shorter cycles. Check surge tank and grease trap
for excessive grease loading. Influent wastewater quality
sample needed.

System biologically under loaded
(white foam)

Notify management entity - Check electrical circuit
breaker to be sure pump is receiving power. Pump should
be checked for failure/influent pipe checked for clogging.

LITTLE OR NO FOAMING

Indication: Very little or no foam is present on the surface of the NIBBLER[®] liquor that
normally has foam.

Cause

Solution

NIBBLER[®] unit is lacking oxygen

1. Check to see if air is coming out the vent system
2. Check screen on blower fan
3. Check vent lines for ponding water (both supply &
discharge lines)
4. Check DO level in NIBBLER[®] unit. If the DO level
below the surface rises 5 to 9 mg/L immediately after the
lid is lifted, check the vent line for blockage.

NIBBLER[®] not being fed

If the NIBBLER[®] unit has not been fed for several days,
there may be no foam present.

System poisoned

A system which has been poisoned may foam excessively.
As it recuperates, it may have no foam at all. Evidence of a
biological kill off may also be present and a high DO will
be present. (see BLACK MAT OR SPECKS -Biological
kill-off)

INSUFFICIENT TURBULENCE IN TANK

Indication: Circles of turbulence on the surface of the mixing liquid do not overlap.

Cause

Solution

Clogged air intake filter

Filter may require cleaning as follows:

1. Remove filter carefully.
2. Using a garden hose, rinse filter from the inside out, until filter is clean, scrubbing stubborn grime if necessary.
3. Replace filter securely in place.

Dirty blower fan

Notify management entity - Fan blades may need cleaning as follows:

1. Disconnect electrical power to fan.
2. Carefully remove side cover to access blades
3. Using paper towels, carefully wipe down blades to remove excess dirt and grime.
4. Replace side cover securely and reconnect electrical power to fan.

Excessive sludge in tank

Notify management entity - A sludge level check should be performed and the tank pumped-out if indicated.

Plugged airtube orifices

Notify management entity - Air tubes should be removed and cleaned.

1. Brush outside of air tube (toilet brush OK)
2. Check inside air tube & clean if necessary.
3. Reinstall air tube.

Plugged exhaust vent

Exhaust vent may be plugged when one or more of the following conditions is apparent:

1. Air audibly leaks around NIBBLER[®] lid and when the lid is opened, there is a release of air pressure.
2. After lids are opened, liquid in the unit bubbles excessively and black specks are observed in the liquid overflow from the air tubes.
3. Liquid level in NIBBLER[®] unit(s) may be low.

NOTE: Using a magnetometer (pressure gauge) you can check the back pressure in the air feed portion of the system. The pressure gauge should have an operational range from 0 to 3 psi. The line between the blower and the NIBBLER[®] units must be drilled and tapped with a 1/4" fitting. Hookup the pressure gauge, measure the back pressure on the system with a NIBBLER[®] unit lid open and record this value. Now close all of the NIBBLER[®] lids and measure the back pressure again. There may be a slight difference but the NIBBLER[®] unit should operate around 0.75 lbs of back pressure and should not exceed 2 lbs. If the back pressure is checked at the system start-up, this value can be used as a troubleshooting guide.

Notify management entity. To correct:

1. Check vent system and vent lines for an obstruction (leaves, bird nest, etc.).
2. Clear obstructions as necessary.

Clogged baffles

Baffles may be clogged when one or more of the following conditions is apparent:

1. High liquid level in tank.
2. Indications of fluctuating liquid levels (water marks) on tank walls.

Notify management entity. To correct:

1. Remove, clean and replace baffle.
2. If baffle continues to clog and the baffle is equipped with a removable screen, it may be necessary to replace the screen with a larger mesh screen or to completely remove the screen from the baffle, leaving the baffle in place.

ODOR

Indication: Strong and/or offensive odors from exhaust vent.

Note: Some odor is to be expected during the first month of operation of all NIBBLER[®] systems, or until the system is biologically stabilized. Some odors may also be expected temporarily during periods of air inversion. If excessive odors persist contact Aqua Test Inc.

Cause

Solution

Excessive bio-growth build-up

Notify management entity. Interior walls of unit and/or air vents may need to be washed down.

Vent outlet too low

Vent system may need to be raised.

Lids not sealed properly

Check lid correct as indicated:

1. Gasket material under sealed lids needs repair or replacement.
2. Bolts missing or need to be tightened.

BLACK MAT OR SPECKS (Biological kill-off)

The NIBBLER[®] treatment system is a biological (living) process that relies upon a healthy aerobic microorganism population. If these microorganisms die, the treatment process is interrupted.

Indication: Black mat (consistency of pudding) floating on mixing liquid or black specks in foam. It should be noted that some black bio-growth can be present in a healthy system. Examination by an experienced technician and/or laboratory analysis may be necessary to determine whether or not a biological kill-off has occurred.

Cause

Solution

Intolerable levels of chemicals
(usually cleaning products)

Notify management entity immediately.
Discontinue (or limit) use of offending product and notify management entity of any changes in cleaning products.

Oxygen supply to unit reduced or cut off

Notify management entity immediately.
Check electrical circuit breaker to be sure blower fan is receiving power.

Note: Since a biological kill-off is particularly threatening to the success of the NIBBLER[®] system, it is important that persons working with the system know how to identify a biological kill-off:

In the field: Evidence of a biological kill-off in the NIBBLER[®] should be apparent during an on-site inspection. The primary indicator of a kill-off is a significant increase in the sludge layer in the bottom of the clarifier since the last inspection. A black mat floating on the mixing liquid or black specks in the foam may also indicate some level of kill off. In addition to visual inspections, Imhoff cone examination and, if possible, microscopic examination of the NIBBLER[®] and clarifier liquor should be made.

In the laboratory: Each effluent sample collected should be observed under a microscope to detect early indications of biological kill-off. A technician familiar with what is considered a healthy microbial population can easily detect early signs of kill-off by the presence of dead microorganisms and/or higher than nominal Food to Microorganism (FM) levels. When an independent laboratory, rather than the monitoring entity, performs the laboratory analyses of wastewater samples, the monitoring technician should perform microscopic examination of samples in the field to determine their viability for laboratory analyses. In doing so, the technician will also note changes in the microbial population.

DISSOLVED OXYGEN

The Dissolved Oxygen (DO) level in wastewater is an important aspect of aerobic treatment and a good tool for troubleshooting. However DO is a very dynamic parameter and can vary considerably from system to system and from component to component. For each system you work on, you will develop a normal set of operating parameters (including DO). The following general statements are related to DO and the NIBBLER[®] system:

- DO measurement is affected by: temperature, barometric pressure (altitude), and salinity. You must input the local altitude into the meter before you measure the DO in the wastewater,
- The DO in the various NIBBLER[®] components can be affected by: the waste strength of the influent, the aeration, the DO in the source water, and ground water infiltration.
- In a grease trap or surge tank the DO is generally between 0.0 and 0.5 mg/L. Ultimately, it is almost always less than 1 mg/L.
- The DO in a NIBBLER[®] unit varies with depth, waste strength, and maturity of the organism population (food to microorganism ratio). The DO in the top 18" of the NIBBLER[®] unit generally ranges between 1 and 3 mg/L. In a properly operating NIBBLER[®] system you will generally find that as you increase the depth the DO decreases. The DO in the sludge at the bottom of the tank may approach zero. The DO in the NIBBLER[®] unit is directly affected by the waste strength and aeration.
- It is possible for a NIBBLER[®] unit to appear to have a very high DO (8-10 mg/L) and have very poor treatment occurring in the unit. If a vent line is obstructed the NIBBLER[®] unit may receive poor aeration when the lids are closed. When the lid is opened the unit appears to have excellent aeration. Since the unit has been operating without good aeration, there will be a small population of aerobic organisms. Therefore, the oxygen level will rise to near saturation levels without a hungry population of organism there to deplete it.
- In the clarifier unit the DO is generally between 0.0 and .2 mg/L.

As previously noted, the DO in different NIBBLER[®] systems can vary. With each system you will develop a set of normal operating parameters including DO. Keeping a good record of the systems performance will help make the long term monitoring and maintenance easier.

CONTROL PANELS

The NIBBLER[®] system generally uses two panels to control the flow. One for the flow from the surge tank to the NIBBLER[®] unit (feed pump) and one to control the sludge return from the clarifier to the grease trap (recirculation pump). Each panel can be ordered for 115 or 230 volt power supply.

NIBBLER[®] CONTROL PANEL

The NIBBLER[®] panel, which can either be a simplex or duplex model, controls the flow from the surge tank to the NIBBLER[®] unit. A specification sheet for this panel is provided in *Section IV*. The NIBBLER[®] panel comes equipped with the following features:

- Timer - A programmable device set to evenly dose the NIBBLER[®] unit(s) 48 times daily, or less for smaller (4 & 6 pod installations), in this case, the NIBBLER[®] unit(s) will be dosed every 2 hours. Timer instructions are provided in *Section IV*
- Elapsed Time Meter, ETM - measures the total accumulated time the pump has run. By keeping track of the elapsed time and the output of the pump in gallons per minute. (GPM), one can calculate the average daily flow through the system since the last site visit.
- Two Cycle Counters. The first counter keeps track of the accumulated number of cycles the pump has run, By using the cycle counts since the last site visit and the calculated Gallons Per Cycle (GPC) one can also check the average daily flow (GPD) through the system and compare it to the flow volume derived from the elapse time meter. The second counter keeps track of the number of times the “off” float activates, i.e. how many times the surge tank was empty since the last site visit.

SLUDGE RETURN PANEL

The second panel used in the NIBBLER[®] system is the clarifier sludge return control panel. This panel controls the pump in the clarifier, which typically returns sludge to the grease trap. The volume returned is normally no more than 5% of the average daily flow. This panel contains the following feature only:

- Timer - A programmable device set to return sludge four times daily In this case, the grease trap will be dosed every 6 hours.

FLOATS

All floats used in the NIBBLER[®] system are “normally open.”

ALARM

Red light (Audible Alarm) - Highwater Alarm

Indicates the surge tank is 75 to 90% full (depending on where the float is set). An audible alarm will sound when this light comes on. The audible alarm can be silenced by pressing the red light on the panel.

CONTACT THE NIBBLER[®] MANAGER IMMEDIATELY

If you continue to use water at the rate you have been you will have a system back-up.

What to do:

1. Verify that the surge tank is full. Look at your as-built diagram and locate the surge tank. Remove the lid at the outlet of this tank using the appropriate allen wrench. The level in this tank should be about 1' from the top of the tank lid (not into the riser) when the 90% alarm activates.

2. If the tank is full check the following equipment:

- Electrical circuit breakers - Are any in the off position? If so, determine if the switch serves the NIBBLER[®] system. If it does, switch the breaker to the "on" position. (Circuit breakers should be clearly marked if they are a part of the NIBBLER[®] system, if it is not clearly marked do not reset breaker)
- Surge tank pump - Locate the NIBBLER[®] control panel. The toggle switch that controls the pump should be in the "auto" position. Make sure this is the NIBBLER[®] control and not the control for the clarifier or drainfield pumps (switches should be clearly marked, if they are a part of the NIBBLER[®] system, if it is not clearly marked do not use). Briefly (no more than two minutes) switch the toggle position from "auto" to "manual" to verify the pump is operating. Liquid levels drop slowly, and may not be apparent, however you may be able to hear the pump humming. If you are still not sure the pump is running, you can feel the vibration in the discharge line. The discharge line should be clearly visible under the surge tank inspection lid at the outlet of the tank.

THE SYSTEM SHOULD ONLY BE RUN IN THE MANUAL MODE IN EMERGENCY SITUATIONS. IMPORTANT: AFTER TESTING THE PUMP, RETURN THE SWITCH TO THE "AUTO" POSITION. DO NOT ALLOW THE PUMP TO RUN IN THE 'MANUAL' MODE FOR MORE THAN TWO MINUTES. IF YOU DISCOVER A PROBLEM WITH THE EQUIPMENT CALL YOUR NIBBLER[®] MANAGER IMMEDIATELY.

3. If no problems are found with the equipment, ask yourself the following questions before you take any action:

- a. Has business volume been high? (Banquets, holiday, special events, etc.)

- b. Has water use been high due to leaking fixtures? (Running toilets, faucets left on, etc.)
- c. Have water using devices been serviced recently? (Refrigeration equipment, air-conditioner, etc.)

If the answers to these questions indicate water usage has been high and flows are likely to remain high, a pumping contractor should be hired to remove some of the excess liquid. Excess liquid is usually pumped directly out of the grease trap, septic tank, or the surge tank. **DO NOT PUMP OUT THE NIBBLER[®] TANK.** Check with your NIBBLER[®] Manager if you have a question as to which tank you should have pumped.

If water usage can be reduced or has curtailed since the time the high water alarm activated, the red light should go out after a short time, indicating that the system is catching up. If this is the case, no further action may be required on your part.

For example, if a banquet is held on Friday causing the alarm to activate near the end of business hours, the system may have time to catch up by Saturday morning. If you anticipate the flows to be high on Saturday and Sunday you may have to call a pumpcr.

Liquid levels should be visually monitored until the red light goes out.

If the red light has not gone out and the liquid levels have not dropped, or have increased over a period of a few hours, call your NIBBLER[®] Manager.

If you need to pump your tanks notify your NIBBLER[®] Manager as soon as possible. That person will need to know which tank was pumped and what volume was removed.

MESSAGE TO THE OWNER / OPERATOR

Each NIBBLER[®] system is as individual as the facility that it serves. Some of the products that you and your staff use, and certain practices within your business may damage the performance of the organisms working in your NIBBLER[®] system. Following is a list of potential problems. This is not a complete list, but it will help you understand the type of things of which you should be aware.

- Every business will eventually grow which will lead to increased flows potentially beyond design. The increased flow may be a result of either increased business or changed management practices to cope with increased business. When a system is found to be over design the first step should be to do a complete system inspection including all downstream components. If everything is okay and there is no ponding in the drainfield a call to the local health agency should be initiated requesting a temporary increase in flow discharged to the drainfield. The requested increase should be for a period of one month with a follow up inspection and report to the Health Department. The goal in increasing the flow is to determine the true flow at the site so that system expansion can be made based on true flows. Also this allows a period for management to work on flow abatement and measure the success of the internal changes by tracking the flows through the system. The flows should never be increased without the permission of the local health department and owner of the facility.
- Cleaning products (vent cleaner, disinfectant, floor cleaner, dish washing products). The disposal of excessive amounts of cleaning products will kill the micro-organisms, which are working in your system.
- Garbage grinders - Everything you put down the drain must be digested in your system. The less you put down your drain the less work your system needs to do and the longer it will last.
- Running water - Your system is designed to treat and dispose of a specific number of gallons per day. Keeping the flow through the system below the design flow will increase the life of your system. Leaking plumbing fixtures, faucets left on, excessive use of water (thawing out a frozen product under running water) all add to the demand on the system. For example in one case a leaking toilet discharged 2500 gallons to a system in 24 hours.
- Excessive peak flows will damage the system.

Please direct any inquiries concerning your NIBBLER[®] system to:

AQUA TEST INC.
P.O. Box 1116
Black Diamond, WA 98010
800-221-3159

SECTION 3

ELECTRICAL INFORMATION

TO BE COMPLETED AFTER CONSTRUCTION

SECTION 4

CONTROL PANEL SPECIFICATIONS



Custom NIBBLER[®] Minnesota Duplex Control Panel

P.O. Box 1116
Black Diamond, WA 98010

Ref: DUPLEX NIBBLER SYSTEM (NON-MERCURY FLOATS - MN)
FOR 240 VAC SINGLE PHASE PUMPS

PANEL DESCRIPTION:

DUPLEX CONTROL

2 SINGLE PHASE INCOMING POWERS
- 240 VAC PUMP VOLTAGE
- 120 VAC CONTROL/ALARM VOLTAGE

NEMA 4X ENCLOSURE

- FIBERGLASS
- 24" X 20" X 12"
- 2 PAD-LOCKABLE LATCHES

ALARM OPTIONS

- 15 WATT RED FLASHING ALARM BEACON
- 83-85 dB ALARM HORN

STANDARD TOGGLE SWITCHES

- 2 HAND-OFF-AUTOMATIC SWITCHES (INTERNAL BRACKET MOUNTED)
- ALARM TEST/NORMAL/SILENCE SWITCH (PANEL SIDE MOUNTED)

CONTROL/ALARM FUSE

AUXILIARY ALARM FUSE

2 IEC RATED CONTACTORS

- 18 AMP RATING

2 PUMP CIRCUIT BREAKERS

- TWO POLE 20 AMP

CUSTOMER SUPPLIED REPEAT CYCLE TIMER

N.O. AUXILIARY 50% LEVEL CONTACTS (120 VAC POWERED)

N.O. AUXILIARY HIGH LEVEL CONTACTS (120 VAC POWERED)

2 ELAPSED TIME METERS

2 PUMP EVENT COUNTERS

TIMER OFF COUNTER

PUMP RATINGS: 240 VAC, 7-15 FLA

2 NORMALLY OPEN NARROW ANGLE MECHANICAL FLOATS (PIPE CLAMP MOUNT)

1 NORMALLY OPEN WIDE ANGLE MECHANICAL FLOAT (PIPE CLAMP MOUNT)

3 FLOAT CONTROL: TIMER ENABLE - 50% LEVEL - HIGH LEVEL ALARM

THE 3-YEAR WARRANTY DOES NOT APPLY TO THE CUSTOMER SUPPLIED TIMER.
AQUA TEST INC. MAKES NO WARRANTIES OF ANY TYPE WITH RESPECT TO COMPONENTS
SUPPLIED BY A CUSTOMER.

WARRANTY – 3 YEAR LIMITED

NOTES

- PANEL SPECIFICATIONS:
 1. CONTROL ALARM PUMP POWER
 120 VAC
 15 W MAX
 2. DASHED LINES REPRESENT FIELD WIRING REQUIRED.
 3. CONNECT GROUND TERMINAL IN BOX TO A GOOD GROUND.

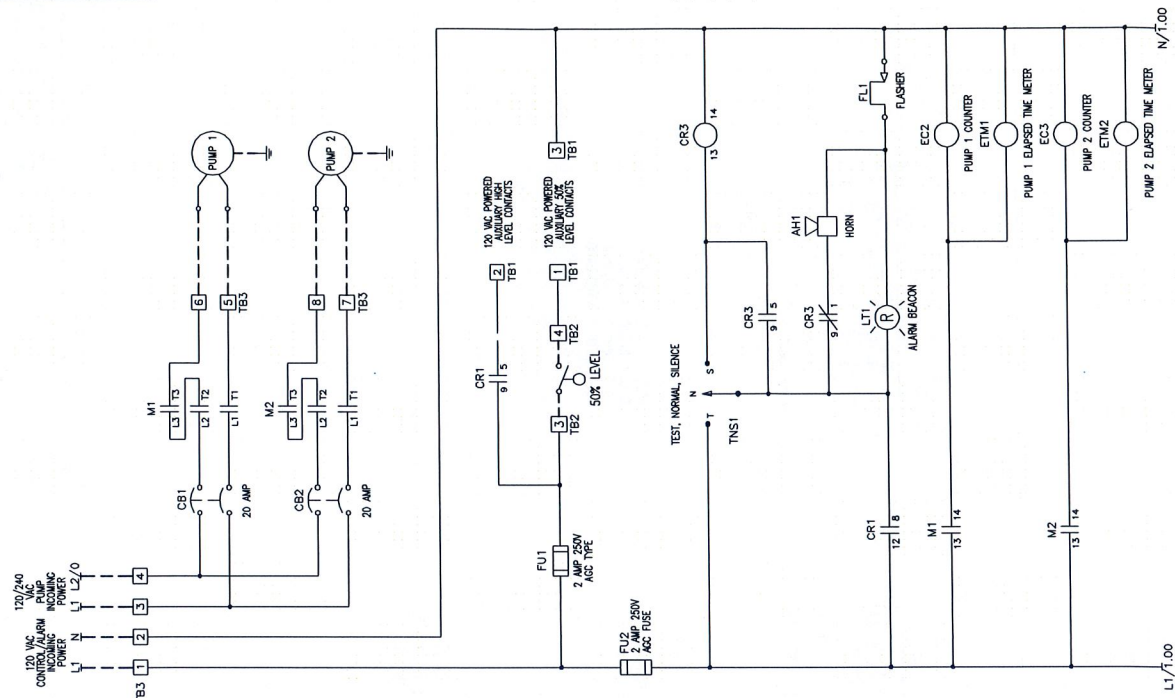

141

142

143

144

145

146

147

148

149

150

151

152

153

154

155

156

157

158

159

160

161

162

163

164

165

166

167

168

169

170

171

172

173

174

175

176

177

178

179

180

181

182

183

184

185

186

187

188

189

190

191

192

193

194

195

196

197

198

199

200

201

202

203

204

205

206

207

208

209

210

211

212

213

214

215

216

217

218

219

220

221

222

223

224

225

226

227

228

229

230

231

232

233

234

235

236

237

238

239

240

241

242

243

244

245

246

247

248

249

250

251

252

253

254

255

256

257

258

259

260

261

262

263

264

265

266

267

268

269

270

271

272

273

274

275

276

277

278

279

280

281

282

283

284

285

286

287

288

289

290

291

292

293

294

295

296

297

298

299

300

301

302

303

304

305

306

307

308

309

310

311

312

313

314

315

316

317

318

319

320

321

322

323

324

325

326

327

328

329

330

331

332

333

334

335

336

337

338

339

340

341

342

343

344

345

346

347

348

349

350

351

352

353

354

355

356

357

358

359

360

361

362

363

364

365

366

367

368

369

370

371

372

373

374

375

376

377

378

379

380

381

382

383

384

385

386

387

388

389

390

391

392

393

394

395

396

397

398

399

400

401

402

403

404

405

406

407

408

409

410

411

412

413

414

415

416

417

418

419

420

421

422

423

424

201
202
203
204
205
206
207
208
209
210
211
212
213
214
215
216
217
218
219
220
221
222
223
224
225
226
227
228
229
230
231
232
233
234
235
236
237
238
239
240
241

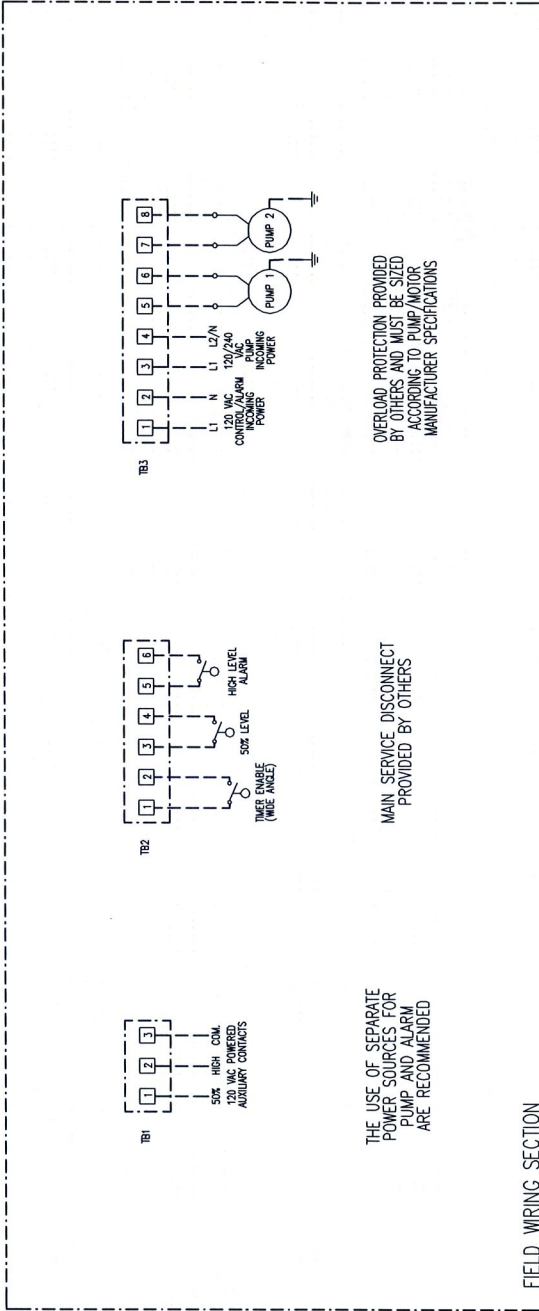

TEMPERATURE RATING OF FIELD INSTALLED CONDUCTORS MUST BE AT LEAST 140 DEG. F. (60 DEG. C.).
 FIELD WIRING TERMINALS AND GROUND LUGS WILL ACCEPT COPPER CONDUCTORS ONLY. TORQUE RATINGS
 OF FIELD WIRING TERMINAL CLAMPING SCREWS IS 7.1-8.9 IN/LBS FOR TB1 & TB2, 10.6-12.3 IN/LBS FOR TB3,
 AND 50 IN/LBS FOR GROUND LUGS.

| | | | | | | | | | | | |
|--|------|----|-------|------|-------|----------|-----|------|----|-------|------|
| NOTICE: THIS DRAWING CONTAINS PROPRIETARY INFORMATION AND IT SHALL BE KEPT CONFIDENTIAL AND NOT REPRODUCED IN WHOLE OR IN PART, WITHOUT PRIOR WRITTEN CONSENT. | | | | | | | | | | | |
| REV | DATE | BY | APP'D | DATE | SCALE | FIG. NO. | REV | DATE | BY | APP'D | DATE |
| 1 | | | | | | | | | | | |
| 2 | | | | | | | | | | | |
| 3 | | | | | | | | | | | |
| 4 | | | | | | | | | | | |
| 5 | | | | | | | | | | | |
| 6 | | | | | | | | | | | |
| 7 | | | | | | | | | | | |
| 8 | | | | | | | | | | | |
| 9 | | | | | | | | | | | |
| 10 | | | | | | | | | | | |
| 11 | | | | | | | | | | | |
| 12 | | | | | | | | | | | |
| 13 | | | | | | | | | | | |
| 14 | | | | | | | | | | | |
| 15 | | | | | | | | | | | |
| 16 | | | | | | | | | | | |
| 17 | | | | | | | | | | | |
| 18 | | | | | | | | | | | |
| 19 | | | | | | | | | | | |
| 20 | | | | | | | | | | | |
| 21 | | | | | | | | | | | |
| 22 | | | | | | | | | | | |
| 23 | | | | | | | | | | | |
| 24 | | | | | | | | | | | |
| 25 | | | | | | | | | | | |
| 26 | | | | | | | | | | | |
| 27 | | | | | | | | | | | |
| 28 | | | | | | | | | | | |
| 29 | | | | | | | | | | | |
| 30 | | | | | | | | | | | |
| 31 | | | | | | | | | | | |
| 32 | | | | | | | | | | | |
| 33 | | | | | | | | | | | |
| 34 | | | | | | | | | | | |
| 35 | | | | | | | | | | | |
| 36 | | | | | | | | | | | |
| 37 | | | | | | | | | | | |
| 38 | | | | | | | | | | | |
| 39 | | | | | | | | | | | |
| 40 | | | | | | | | | | | |
| 41 | | | | | | | | | | | |

SJE-Rhombus

PROJECT NO. PRO12-637
 QUOTE NO. 20485
 TITLE
 PROJECT-EST

SECTION 5

BLOWER SPECIFICATIONS



Blower System Design Tips

In order to utilize your regenerative blower most efficiently, proper system design is essential. The most important thing to recognize is that by utilizing large diameter plumbing, friction losses in plumbing can be greatly reduced. Here are some guidelines to use when setting up your blower system:

1. The plumbing should at least be the same size as the blower port or ideally one size larger (example - blower has ports that are 1-1/2" NPT, plumbing should be 2" NPT). The plumbing should remain this size until it has reached the location of the work area.
2. Plumbing for Separate Drive Blowers operating above 3500 RPM should be at least one pipe size larger than the blower ports.
3. Elbows create additional friction which causes pressure loss and back pressure. Plumbing at least one pipe size larger than the blower pipe ports minimizes the friction loss they create.
4. The pressure/vacuum relief valve should be installed in a "T" which is at least one pipe size larger than that of the exhaust of the blower. To properly protect a large horsepower blower, set the relief value to limit the blower's duty to 5 in. H₂O below its continuous duty rating.
5. Operating the blowers at high altitude decreases their maximum pressure or vacuum duty rating. If this is a consideration, review the information on Fan Laws in the Application Engineering section of this catalog.
6. The exhaust air temperature of the blowers increases with increasing duty. At duties over 70 in. H₂O it is too hot for most plastic pipe. Metal pipe must be considered. To prevent danger of burns, access to these pipes should be limited, guarded or marked "Danger Hot."

Performance Data

The performance data shown in this catalog was determined under the following conditions:

- Line voltage @ 60 Hz. 230V or 460V for three-phase units. 115V or 230V for single-phase units.
- Line voltage @ 50Hz. 220V for three-phase or single-phase units.
- Units in a temperature stable condition.
- Delivery measurements made with output port throttled.
- Suction measurements made with input port throttled.
- Test Conditions: Inlet air density at 0.075 lbs. per cu.ft. [20°C (68°F), 29.92 in. Hg (14.7 PSIA)].
- Normal performance variations on the resistance curve within ± 10% of supplied data can be expected.

Pictorial and dimensional data is subject to change without notice.

The information presented in this catalog is based on technical data and test results of nominal units. It is believed to be accurate and is offered as an aid in the selection of Gast products. It is the user's responsibility to determine suitability of the product for intended use and the user assumes all risk and liability whatsoever in connection therewith.

Gast can also provide CE compliant blowers with BSP threads, as well as customized blowers for specific applications. Consult a Gast Representative/Distributor for more information.

Environmental and application conditions may affect advertised life.

Warning:

Models Without Explosion-Proof Motors Should Not Pump Combustible Gases or Be Used In Combustible Ambients



Performance Table

| MODEL/ SERIES | POWER RATING @ 60 Hz | | FREE AIR FLOW | | | | MAXIMUM PRESSURE | | | | MAXIMUM VACUUM | | | |
|---|-------------------------|---------------|---------------|-------------|-------------|-------------|--------------------|------------|-------------|-------------|--------------------|-----------|-------------|-------------|
| | hp | kW | cfm | | m³/h | | " H ₂ O | | mbar | | " H ₂ O | | mbar | |
| | | | 50 Hz | 60 Hz | 50 Hz | 60 Hz | 50 Hz | 60 Hz | 50 Hz | 60 Hz | 50 Hz | 60 Hz | 50 Hz | 60 Hz |
| Standard Motor Mounted Models | | | | | | | | | | | | | | |
| R1* | 1/8 | 0,09 | 23 | 27 | 39 | 46 | 21 | 28,5 | 52 | 71 | 20 | 26,5 | 50 | 66 |
| R2* | 1/3, 1/2 | 0,25, 0,37 | 33 | 42 | 56 | 71 | 30 | 39 | 75 | 97 | 25 | 35 | 62 | 87 |
| R3* | 1/2 | 0,37 | 43-44 | 52-53 | 73-75 | 88-90 | 31-40 | 43-55 | 77-100 | 107-137 | 28-35 | 40-50 | 70-87 | 100-125 |
| R4* | 1 | 0,75 | 75 | 92 | 127 | 156 | 38 | 52 | 95 | 130 | 35 | 48 | 87 | 120 |
| R4P* | 1 1/2 | 1,1 | 110 | 127 | 187 | 216 | 50 | 65 | 125 | 162 | 45 | 60 | 112 | 149 |
| R5* | 2 1/2 | 1,86 | 133 | 160 | 226 | 272 | 50 | 65 | 125 | 162 | 47 | 60 | 117 | 149 |
| R6* | 2 1/2- 5 | 1,86- 3,73 | 180 | 207- 215 | 306 | 352- 365 | 40- 78 | 45- 105 | 100- 194 | 112- 262 | 50- 70 | 55- 88 | 125- 194 | 137- 262 |
| R6P* | 3 1/2- 5 1/2 | 2,6- 4,1 | 225- 245 | 265- 290 | 382- 416 | 450- 493 | 50- 85 | 30- 110 | 125- 212 | 75- 274 | 50- 85 | 35- 90 | 126- 212 | 87- 224 |
| R6PP* | 11 | 8,2 | 420 | 520 | 714 | 884 | 75 | 95 | 187 | 237 | 65 | 80 | 162 | 199 |
| R7* | 10 | 7,46 | 350 | 420 | 595 | 714 | 115 | 125 | 286 | 311 | 90 | 110 | 224 | 274 |
| R7P* | 18 | 13,4 | 666 | 795 | 1132 | 1351 | 90 | 105 | 284 | 262 | 85 | 95 | 212 | 237 |
| R9* | 15 | 11,3 | 585 | 680 | 994 | 1155 | 125 | 125 | 311 | 311 | 105 | 115 | 262 | 286 |
| R9P* | 30 | 22,4 | 1140 | 1350 | 1937 | 2294 | 110 | 125 | 274 | 311 | 100 | 110 | 249 | 274 |
| High Pressure Motor Mounted Models | | | | | | | | | | | | | | |
| R4H* | 6 | 4,5 | 107 | 128 | 182 | 217 | 284 | 284 | 707 | 707 | 183 | 183 | 456 | 456 |
| R6PS* | 11 | 8,2 | 230 | 280 | 391 | 476 | 145 | 170 | 361 | 423 | 110 | 130 | 274 | 324 |
| R7S* | 18 | 13,4 | 350 | 420 | 595 | 714 | 170 | 200 | 423 | 498 | 130 | 150 | 324 | 374 |
| R9S* | 30 | 22,4 | 585 | 660 | 994 | 1121 | 208 | 222 | 518 | 553 | 142 | 149 | 354 | 371 |
| Explosion Proof Motor Models | | | | | | | | | | | | | | |
| R3105N-50 | 1/2 | 0,37 | 44 | 53 | 75 | 90 | 31 | 43 | 77 | 107 | 28 | 40 | 70 | 100 |
| R4110N-50 | 1 | 0,75 | 74 | 92 | 126 | 156 | 38 | 51 | 95 | 127 | 35 | 48 | 87 | 120 |
| R4310P-50 | 1 | 0,75 | 74 | 92 | 126 | 156 | 38 | 51 | 95 | 127 | 35 | 48 | 87 | 120 |
| R4P115N-50 | 1 1/2 | 1,1 | 112 | 133 | 190 | 226 | 45 | 65 | 112 | 162 | 40 | 60 | 100 | 149 |
| R5125Q-50 | 2 | 1,5 | — | 160 | — | 272 | — | 55 | — | 137 | — | 60 | — | 149 |
| R5325R-50 | 2 | 1,5 | 133 | 160 | 226 | 272 | 50 | 65 | 125 | 162 | 47 | 65 | 117 | 162 |
| R6130Q-50 | 3 | 2,2 | 180 | 215 | 306 | 365 | 75 | 60 | 187 | 149 | 65 | 70 | 162 | 174 |
| R6340R-50 | 4 | 3,0 | 180 | 215 | 306 | 365 | 75 | 100 | 187 | 249 | 65 | 80 | 162 | 199 |
| R6P155Q-50 | 5 1/2 | 4,1 | 235 | 280 | 399 | 476 | 80 | 95 | 199 | 237 | 65 | 85 | 162 | 212 |
| R6P355R-50 | 6 | 4,5 | 232 | 280 | 394 | 476 | 80 | 100 | 199 | 249 | 65 | 85 | 162 | 212 |
| R7100R-50 | 10 | 7,5 | 350 | 425 | 595 | 722 | 90 | 100 | 224 | 249 | 85 | 110 | 212 | 274 |
| Separate Drive Models | | | | | | | | | | | | | | |
| SDR4 | 4 | 3,0 | 147 | | 250 | | 110 | | 274 | | 90 | | 224 | |
| SDR5 | 10 | 7,5 | 240 | | 408 | | 152 | | 379 | | 120 | | 299 | |
| SDR6 | 15 | 11,2 | 300 | | 510 | | 155 | | 386 | | 135 | | 336 | |

*Models equipped with UL and CSA certified motors. (except R1102K (12v DC))

Performance Curves - Low Range for Pressure/Vacuum

Motor mounted series R1, R2, R3, R4, R4P, R5

Performance at 60 Hz

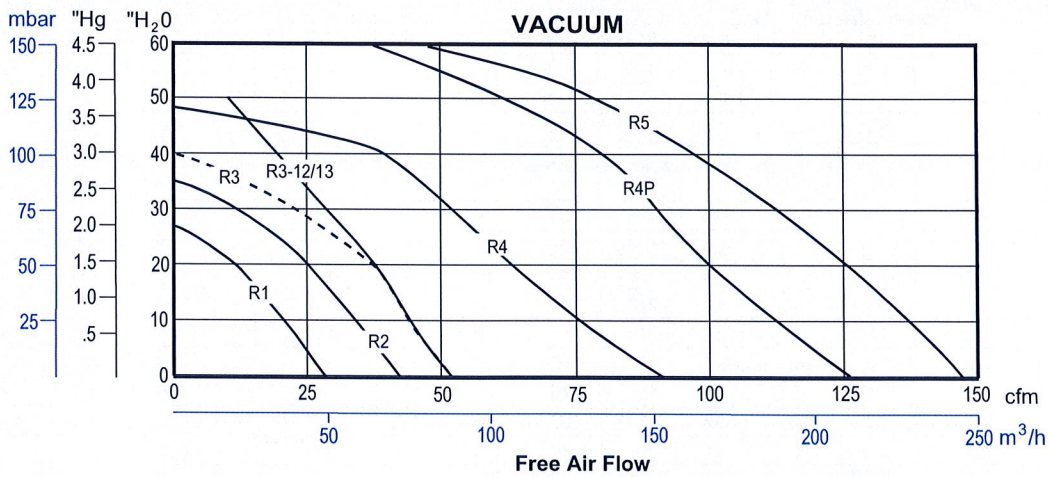
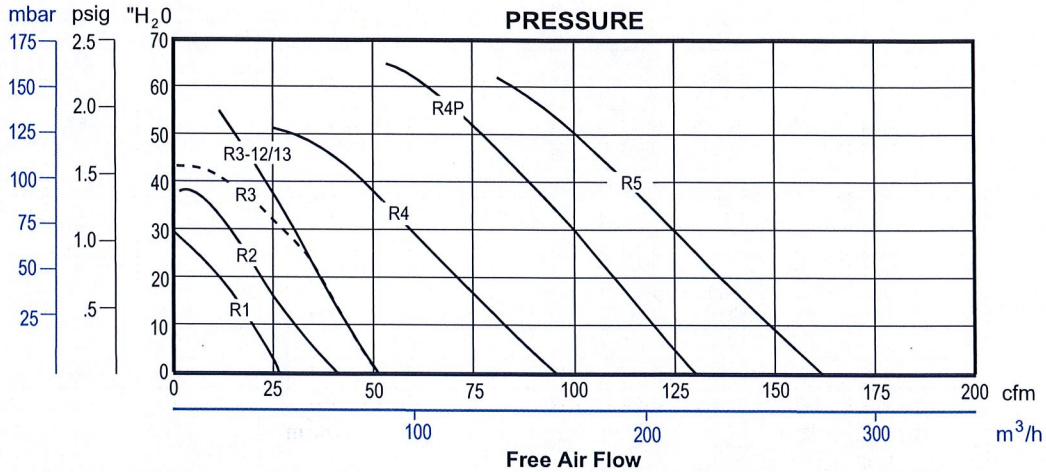

Gast advertises blower performance in Free Air Flow, or air subjected to only atmospheric pressure. (See above curves)
 Some blower manufacturers advertise vacuum performance in CFM Inlet Air - measurement of the suction of air at a specific temperature at the inlet port and a specific discharge pressure at the exhaust port, which can be perceived as enhanced performance over Free Air Flow rated blowers. Therefore, we are also providing the following vacuum performance for Gast blowers in CFM Inlet Air for comparison to other blower manufacturer's advertising.

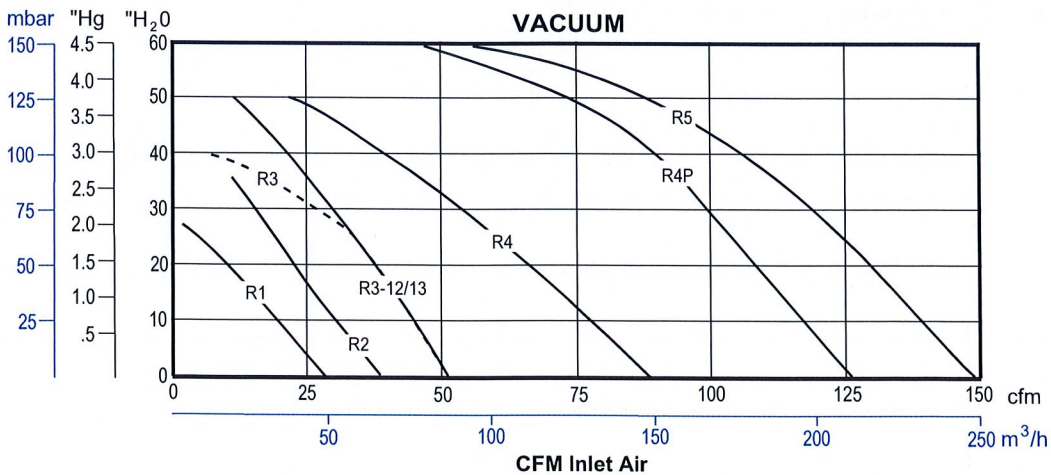



R4 SERIES

MODELS R4110-2, R4310A-2, R4310B-1

MAX. PRESSURE – 52"H₂O (60 Hz), 38"H₂O (50 Hz)

MAX. VACUUM – 48"H₂O (60 Hz), 35"H₂O (50 Hz)

MAX. AIR FLOW – 92 CFM (60 Hz), 75 CFM (50 Hz)

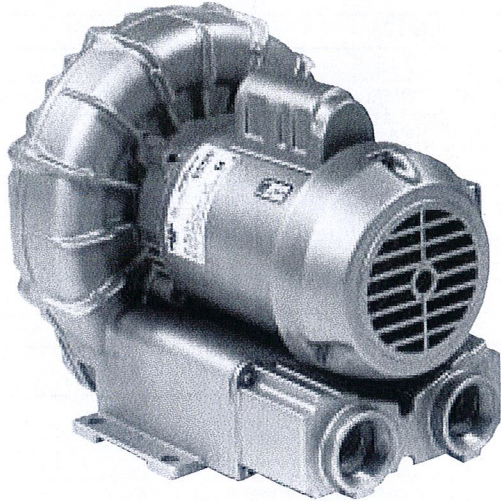

PRODUCT FEATURES

- Rugged construction, low maintenance
- Oilless operation
- UL and CSA approved TEFC motors with permanently sealed ball bearings
- Automatic restart thermal protection on single phase motors
- Aluminum blower housing, impeller and cover
- Can be operated with no air flow through unit
- Can be mounted in any plane
- Inlet and outlet have internal muffling

RECOMMENDED ACCESSORIES

- Pressure gauge AJ496
- Inlet filter AJ126D (pressure)
- Vacuum gauge AJ497
- Inline filter AJ151D (vacuum)
- Muffler AJ121D
- Relief valve AG258
- Liquid separator RMS160 (vacuum)
- Foam replacement kit K902

Product Dimensions (in. mm)

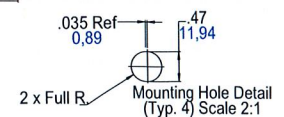
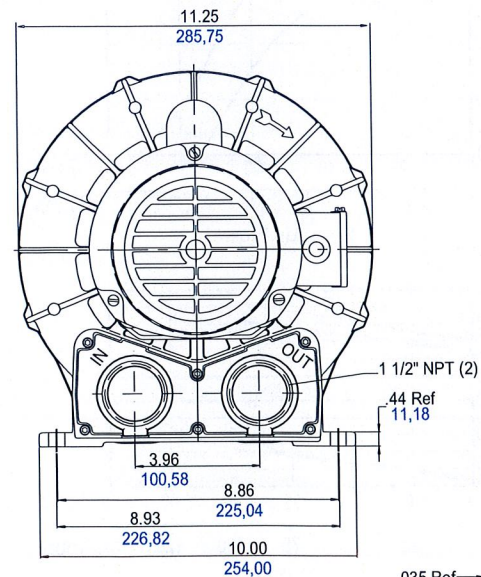
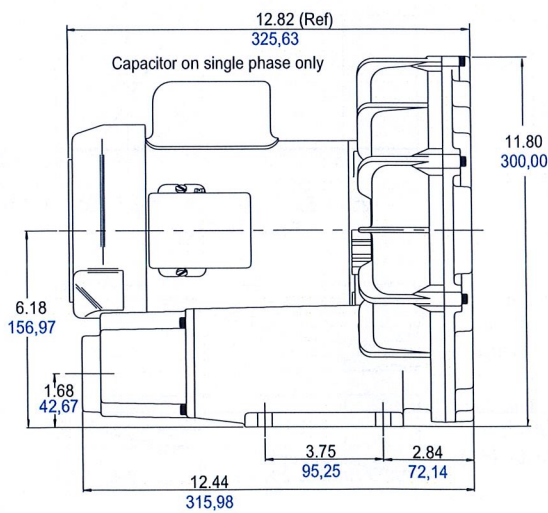



Product Specifications

| MODEL NUMBER | | R4110-2 | R4310A-2 | R4310B-1 |
|-------------------------------|-------|---------------|-------------------|----------|
| Motor Enclosure | | TEFC | TEFC | TEFC |
| HP/kW | 60 Hz | 1.0/0,75 | 1.0/0,75 | 1.0/0,75 |
| | 50 Hz | .6/0,45 | .6/0,45 | - |
| Voltage | 60 Hz | 115/208-230-1 | 208-230/460-3 | 575-3 |
| | 50 Hz | 110/220-240-1 | 190-220/380-415-3 | - |
| Amps | 60 Hz | 9.8/5.2-4.9 | 3.4-3.2/1.6 | 1.25 |
| | 50 Hz | 9.0/4.5-5.7 | 2.6-3.3/1.3-1.4 | - |
| Starting Amps | 60 Hz | 31.2 @ 230V | 26.5 @ 230V | 7.6 |
| | 50 Hz | 34 @ 220V | 28.4 @ 220V | - |
| Insulation Class | | B | B | B |
| Recommended NEMA Starter Size | | 0/00 | 00/00 | 00 |
| Net Weight (lbs/kg) | | 41/18,6 | 41/18,6 | 41/18,6 |

Product Performance

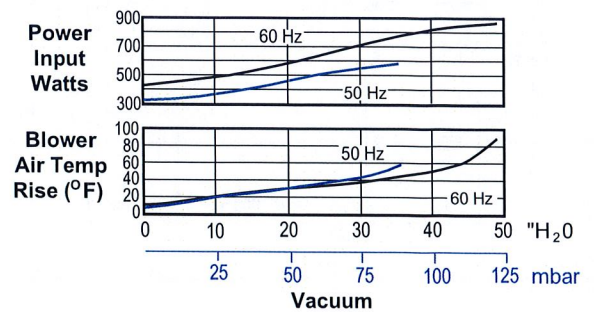
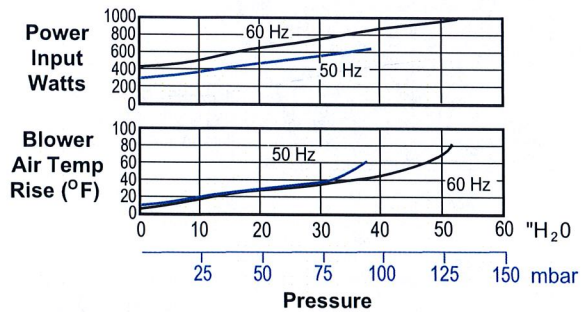
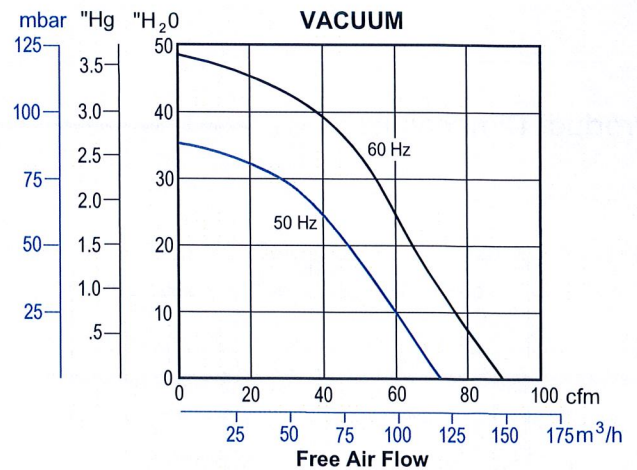
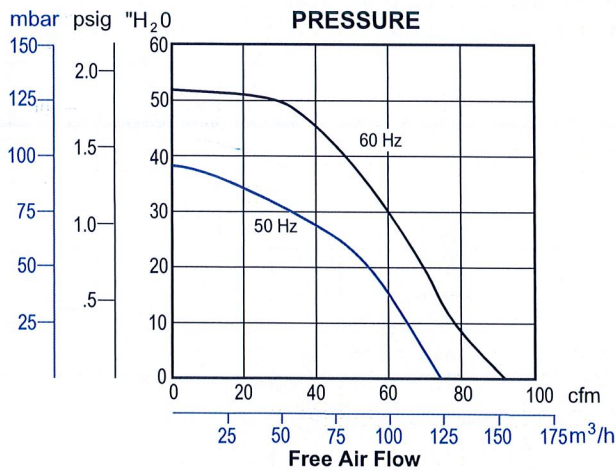

SECTION 6

PUMP SPECIFICATIONS

"QUALITY PUMPS SINCE 1939"

Product information presented here reflects conditions at time of publication. Consult factory regarding discrepancies or inconsistencies.

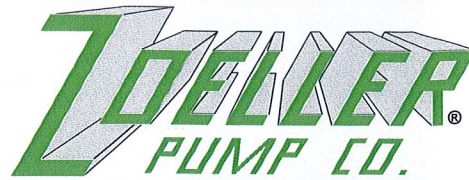

SECTION: 3.20.014

FM1919

0504

Supersedes

0403

MAIL TO: P.O. BOX 16347 • Louisville, KY 40256-0347
SHIP TO: 3649 Cane Run Road • Louisville, KY 40211-1961
(502) 778-2731 • 1 (800) 928-PUMP • FAX (502) 774-3624

visit our web site:
www.zoeller.com

ZOELLER ON-SITE WASTEWATER PRODUCTS

INTRODUCING ZOELLER ON-SITE "DOSE-MATE" PUMPS

COMPARE THESE FEATURES

- Durable cast iron construction.
- Model 151 comes standard with a glass-filled polypropylene base.
- Corrosion resistant powder coated epoxy finish.
- Stainless steel lifting handle.
- Assembled with stainless steel bolts.
- Non-clogging engineered thermoplastic vortex impeller design.
- Model 151 - 1/3 HP passes 1/2" spherical solids.
- Model 152 - .4 HP passes 3/4" spherical solids.
- Model 153 - 1/2 HP passes 3/4" spherical solids.
- Motor - 60 Hz, 3450 RPM, oil-filled, hermetically sealed, automatic reset thermal overload protected.
- Carbon/Ceramic seals.
- Upper sleeve bearing and lower ball bearing running in bath of oil.
- 20 ft. UL Listed power cord with molded 3-wire plug.
- 1 1/2" NPT vertical discharge.
- BN and BE standard models include a 20 ft. variable level float switch.
- Operates at temperatures to 130°F (54°C) in effluent applications.
- All models include a 1 1/2" x 2" PVC adapter fitting.

Note: The sizing of effluent systems normally requires variable level float(s) controls and properly sized basins to achieve required pumping cycles or dosing timers with nonautomatic pumps.

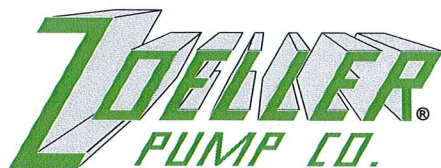

Manufacturers of . . .



"QUALITY PUMPS SINCE 1939"

151/152/153 EFFLUENT SERIES

(For Pump Prefix Identification see News & Views 0052)

"DOSE-MATE"

FOR SEPTIC TANK - LOW PRESSURE PIPE (LPP)
AND ENHANCED FLOW STEP SYSTEMS



Tested to UL Standard UL778
and Certified to CSA
Standard CSA22.2 No. 108

MODELS AVAILABLE

- N151/N152/N153 & E151/E152/E153 nonautomatic
- BN151/BN152/BN153 & BE151/BE152/BE153 packaged with Piggyback Variable Level Float Switch
- 1/3, .4 & 1/2 HP, 1Ph 115V or 230V

EFFLUENT
SUBMERSIBLE
1 1/2" NPT DISCHARGE



Model N152/N153
High Head
Effluent



**POWDER
COATED
TOUGH™**

Model BN152/BN153
High Head
Effluent

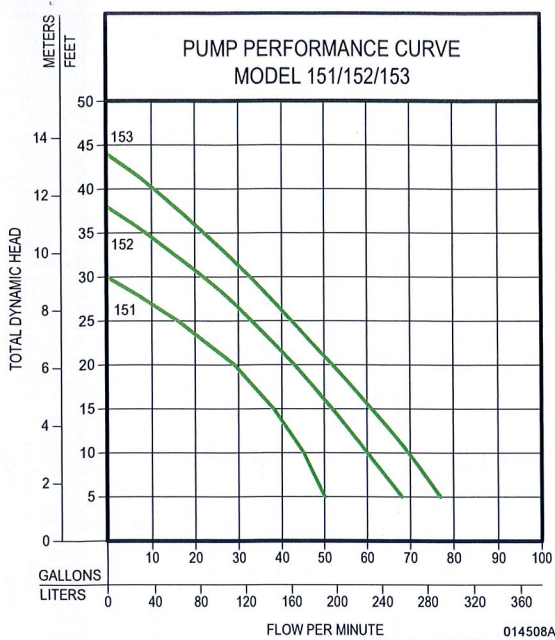

TOTAL DYNAMIC HEAD/FLOW
PER MINUTE
EFFLUENT AND DEWATERING

| MODEL | | 151 | | 152 | | 153 | |
|----------------|--------|---------------|--------|----------------|--------|----------------|--------|
| Feet | Meters | Gal. | Liters | Gal. | Liters | Gal. | Liters |
| 5 | 1.5 | 50 | 189 | 69 | 261 | 77 | 291 |
| 10 | 3.0 | 45 | 170 | 61 | 231 | 70 | 265 |
| 15 | 4.6 | 38 | 144 | 53 | 201 | 61 | 231 |
| 20 | 6.1 | 29 | 110 | 44 | 167 | 52 | 197 |
| 25 | 7.6 | 16 | 61 | 34 | 129 | 42 | 159 |
| 30 | 9.1 | -- | -- | 23 | 87 | 33 | 125 |
| 35 | 10.7 | -- | -- | -- | -- | 22 | 85 |
| 40 | 12.2 | -- | -- | -- | -- | 11 | 42 |
| Shut-off Head: | | 30 ft. (9.1m) | | 38 ft. (11.6m) | | 44 ft. (13.4m) | |

014508B

CONSULT FACTORY FOR SPECIAL APPLICATIONS

- Timed dosing panels available.
- Electrical alternators, for duplex systems, are available and supplied with an alarm.
- Variable level control switches are available for controlling single phase systems.
- Double piggyback variable level float switches are available for variable level long and short cycle controls.
- Sealed Qwik-Box available for outdoor installations. See FM1420.
- Over 130°F. (54°C.) special quotation required.

151/152/153 Series

| Model | 151/152/153 MODELS | | | Control Selection | |
|-------|--------------------|------|------|-------------------|--------|
| | Volts-Ph | Mode | Amps | Simplex | Duplex |
| N151 | 115 | 1 | 6.0 | 1 | 2 or 3 |
| BN151 | 115 | 1 | 6.0 | Included | 2 or 3 |
| E151 | 230 | 1 | 3.2 | 1 | 2 or 3 |
| BE151 | 230 | 1 | 3.2 | Included | 2 or 3 |
| N152 | 115 | 1 | 8.5 | 1 | 2 or 3 |
| BN152 | 115 | 1 | 8.5 | Included | 2 or 3 |
| E152 | 230 | 1 | 4.3 | 1 | 2 or 3 |
| BE152 | 230 | 1 | 4.3 | Included | 2 or 3 |
| N153 | 115 | 1 | 10.5 | 1 | 2 or 3 |
| BN153 | 115 | 1 | 10.5 | Included | 2 or 3 |
| E153 | 230 | 1 | 5.3 | 1 | 2 or 3 |
| BE153 | 30 | 1 | 5.3 | Included | 2 or 3 |

CAUTION

All installation of controls, protection devices and wiring should be done by a qualified licensed electrician. All electrical and safety codes should be followed including the most recent National Electric Code (NEC) and the Occupational Safety and Health Act (OSHA).

Model 151

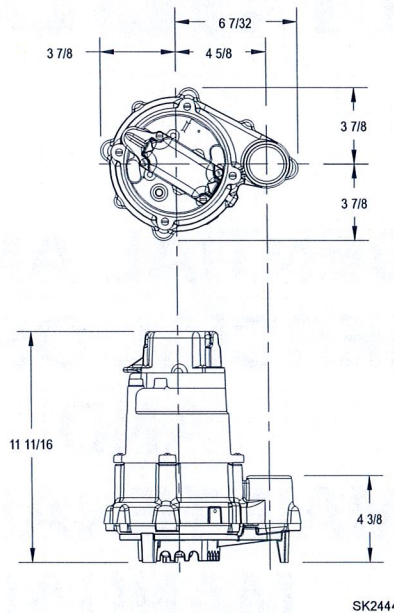

Models 152 / 153

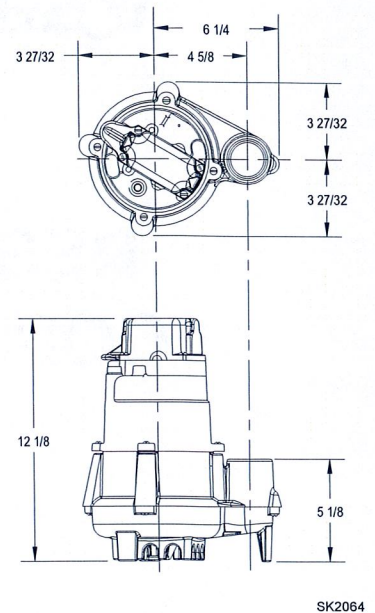

SELECTION GUIDE

1. Single piggyback variable level float switch or double piggyback variable level float switch. Refer to FM0477.
2. See FM0712 for correct model of Electrical Alternator E-Pak.
3. Variable level control switch 10-0225 used as a control activator, specify duplex (3) or (4) float system.

RESERVE POWERED DESIGN

For unusual conditions a reserve safety factor is engineered into the design of every Zoeller pump.



<http://www.zoeller.com>

ZOELLER
PUMP CO.

MAIL TO: P.O. BOX 16347
Louisville, KY 40256-0347
SHIP TO: 3649 Cane Run Road
Louisville, KY 40211-1961
(502) 778-2731 • 1 (800) 928-PUMP
FAX (502) 774-3624

Manufacturers of..

"QUALITY PUMPS SINCE 1939"

The icon for "The NIBBLER" is a square with rounded corners, containing a green liquid with white bubbles and several black outlines of globes or spheres.

**The
NIBBLER®**

**RESIDENTIAL AND LIGHT
COMMERCIAL OPERATION
AND
MAINTENANCE
MANUAL**

TABLE OF CONTENTS

Introduction

Section I - Unit Description

Components List

Operational Description

Section II - Operations & Maintenance

Inspection & Maintenance

Troubleshooting

Appendix A - Example Systems

NIBBLER[®] CBP – 1 Unit, 2 Units, & 3 Units

Appendix B - Blower Specifications

Appendix C - Field Checklist Form

Appendix D - Glossary

INTRODUCTION

The NIBBLER® CBP is a device that is inserted into your septic tank, which is installed at the outlet of the tank and can perform three basic functions:

Provides wastewater treatment (reducing the waste strength being discharged to the drainfield)

Discharges a flow high in dissolved oxygen - improving the drainfield efficiency

“Lifts” and recirculates sewage to the first compartment for enhanced treatment

Section I
Unit Description

COMPONENTS LIST

| | |
|-----------------|--|
| Blower | A one-eighth horse power blower for one CBP or a one or two PODS. And a third horse power blower for three PODS delivers the air. The blower is designed to run continuously. It should have a fine mesh screen (1/16") over the inlet to the blower |
| Air Supply Line | The airline delivers air to the riser containing the NIBBLER® CBP. |
| Flex Line | The flex line and union are the final adjustable connection to the air supply line and the internal air line that delivers to the draft tube. |
| PVC CAGE | The removable PVC cage holds draft tube and the trickle media. |
| Draft Tube | A 3" PVC tube centered in the 18" PVC vault. Air discharged in the draft tube, displaces liquid in the tube and forces it out the top. |
| Air Manifold | The air manifold is unit with multiple orifices for flushing the lower media. |
| Submerged Media | Submerged media are 3.5" round plastic spheres contained in the vault below the liquid level. This media provides surface area for microorganisms to attach. |
| Legs | PVC legs hold the unit off the bottom of the tank. |
| Vault | The unit is contained within an 18' diameter PVC vault. |

OPERATIONAL DESCRIPTION

Raw sewage enters the septic tank at the inlet. In moving through the tank, settling and partial separation of solids occurs. Some tanks have a baffle wall that splits the tank into two compartments. The NIBBLER[®] CBPs are typically mounted at the outlet of the tank, which would be in the second compartment of a two-compartment tank.

Liquid is drawn into the NIBBLER[®] CBP through the bottom of the unit and into the submerged media and oxygenated zone within the vault. Wastewater passes through the media and is drawn into the draft tube in the center of the vault. The air released into the unit forces the flow out the top of the draft tube. This may be observed as the liquid splashes out the top, similar to the effect of a coffee percolator. This splashing effect also re-circulates the sewage around the second compartment of the tank aiding in the distribution of oxygen.

A portion of the flow discharged by the draft tube is collected and distributed by the discharge spoon mounted at the top of the unit. The spoon collects a metered portion of the flow and then discharges it to the first compartment. The amount of flow discharged is determined by the amount of spoon exposed to the flow bubbling out the top of the unit. The re-circulated sewage aids in odor control and enhances the treatment process.

The CPB units are equipped with the center air discharge in the draft tube and with a lower air manifold. As discussed in the previous section the center draft tube moves and oxygenates the sewage while the lower air manifold assists in scrubbing the media and providing an additional source of oxygen.

Section II

Operations & Maintenance

INSPECTION & MAINTENANCE

The NIBBLER[®] CBP system is a living environment that must be kept healthy to efficiently do its job. In order to do this and also meet the terms of the NIBBLER[®] CBP warranty, there is a minimal amount of inspection and service that needs to be regularly performed. We recommend inspecting NIBBLER[®] CBP system at least every six months.

1. Site Observation

- A. Before opening the system, look around for any wet areas or patches of lush green grass near the chamber. This may mean there is a broken pipe or a loose or damaged riser lid. Listen for a low splashing noise (prior to opening the unit)
- B. A properly operating system should not have an odor. If you smell an obvious odor before the lid is opened, check to make sure that the lid is tight and not damaged. If this is not the cause of the odor, the system may be biologically overloaded or the vent line may be blocked. To mitigate any such odor, proper venting is recommended.
- C. Also before opening the lid, listen closely for a gurgling sound - an indication that the NIBBLER[®] CBP unit is properly percolating effluent out the top. If a faint gurgling sound cannot be heard through the lid, check to be sure the blower is running.

2. Open Lid & Inspect the Unit

- A. When opening the lid, you should see treated effluent splashing up and out of the center tube and raining onto the top of the unit. If the treated wastewater is not splashing, the blower may not be working properly.
- B. After lifting lid take notice immediately to see if black specs are mixed in with the sewage percolating out the draft tube. The presence of black specs indicates that the unit is not ventilated properly.
- C. If the blower is not running, check the breakers to make sure power is being delivered to the unit.
- D. If the blower is running but not pumping air into the system, it may be running in reverse. To solve this problem, turn the fan off and manually spin it in the opposite direction it was running and then turn the power back on.
- E. Check to be sure that the intake filter is clean and that the source of fresh air is not blocked

3. Check Liquid Level & Measure Dissolved Oxygen

- A. If the blower is working properly you will next want to check the flood level in the tank. The liquid level in the tank should be at the invert of the outlet pipe.
- B. If the flood level in a Lift model is too high, check to see if there is a blockage between the outlet and any downstream components.
- C. If the liquid level is more than 2” below the invert of the outlet the venting may be blocked, Investigate the venting to be sure its not blocked.
- D. If instruments are available, measure and record the Dissolved Oxygen (DO) level from effluent splashing out the draft tube. Lower DO levels (e.g., under 2.0 mg/L) is an indication that the NIBBLER[®] CBP unit is not performing as well as should be expected and may need cleaning. Measure the pH and Temperature; A pH below 6.0 indicates system toxicity from medication or chemicals.

4. Measure Sludge and Scum Levels

- A. Using a Sludge Judge or other device, measure the sludge and scum levels in the first compartment of the septic tank. The combined sludge and scum level should not occupy more than 30 % of the tank capacity.
- B. The sludge level should not come closer than 2” from the NIBBLER[®] CBP vault bottom.
- C. The sludge or scum levels in the first compartment should not comprise more than 30 % of the working volume.
- D. If sludge or scum levels should exceed those recommended, the tank should be pumped.

5. Inspect Media

- A. A properly operating unit will have a small amount of growth clinging to the media in the upper region but will not be so thick that it reduces flow. If the growth is black or hinders flow through the media, the media in the upper region should be cleaned.

6. Cleaning the Media

- A. Turn off the draft tube air supply and activate the lower flushing manifold.
- B. Allow the lower flushing manifold to operate for 20 minutes.
- C. Turn on the draft tube air supply and turn off the lower flushing manifold.

D. Wash down the upper media with a hose and jet nozzle.

E. Replace the lid and clean up the surrounding area.

TROUBLESHOOTING

Odors

- Risers or lids may be leaking.
- System may be vented through plumbing
- Venting pipe may be clogged.
- Bark filter requires new bark.
- Media has excessive biological growth.
- System may be biologically overloaded or may have encountered a toxic shock.
 - Increase air to the unit
 - Connect inlet side of tank to the treatment side

To mitigate any such odor, proper venting through a chambered bark or carbon filter is recommended.

Insufficient Splashing Out the Draft Tube

- Check the liquid level in the tank. If the liquid level in the tank is 8” below the top of the 3” gravity discharge pipe, this may be a normal operating condition (low flow condition).
- Check to make sure the blower is running. If the blower is not running, check the breakers to make sure power is being delivered to the unit.
- Check the inlet screen to the blower. Clean if necessary.
- Check to be sure the fresh air source is not obstructed.
- If the blower is running but not pumping air into the unit, it may be running in reverse. To solve this problem, turn the fan off and manually spin it in the opposite direction it was running and then turn the power back on.
- Media may be clogged. Check the submerged media and if necessary, clean it.
- Check the line between the blower and the unit for leaks or breaks.
- Check to the air supply valves are in the correct position.
- Check to be sure the vent line is not plugged.

Liquid Level Too High

- Check for ponding in the drainfield
- If the flood level is too high, check for obstructions downstream.
- Groundwater may be leaking into the tank.
- The home may be using excessive amounts of water. Check water use records or pump data if available.

Liquid Level Too Low

- Check for venting blockage as the tank may be pressurized
- The tank may have a leak.

Appendix A

Example Systems



3-CBP AquaTest NIBBLER® CBP COMPONENTS 1-800-221-3159

NOTE:
ALL NIBBLER® CBP COMPONENTS SHALL BE OBTAINED
AS A PACKAGE FROM AquaTest Inc. 1-800-221-3159

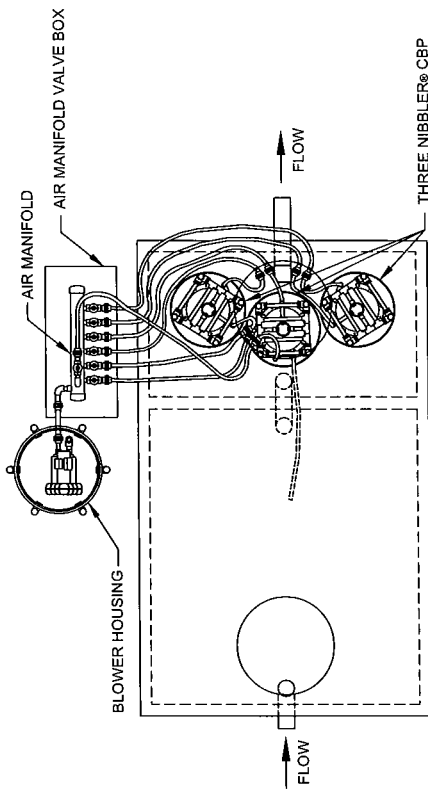

PLAN VIEW
NTS

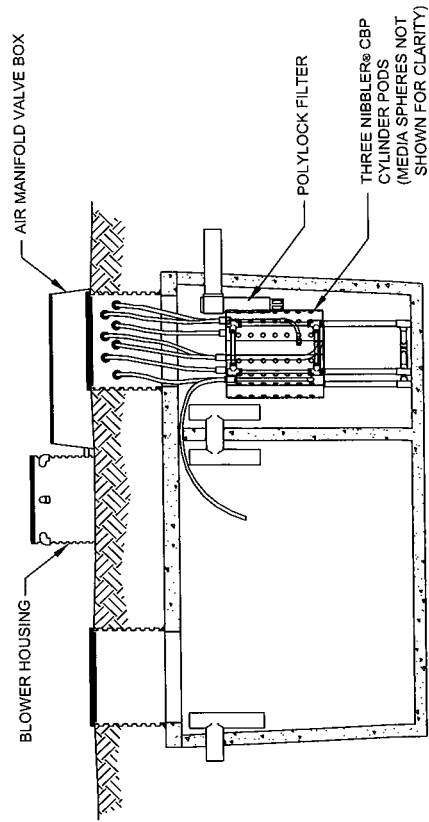

ELEVATION
NTS

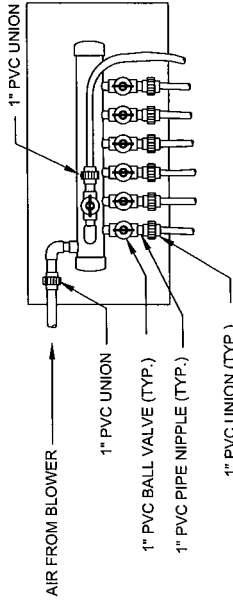

AIR MANIFOLD VALVE BOX DETAIL
NTS

| AquaTest NIBBLER® CBP COMPONENTS | |
|----------------------------------|--------------------------------------|
| QTY. | DESCRIPTION |
| 3 | AquaTest NIBBLER® CBP UNIT |
| 3 | SET NIBBLER® CBP LEGS |
| 3 | NIBBLER® CBP STABILIZER |
| 1 | NIBBLER® CBP PORT MANIFOLD - 6 PORTS |
| 14 | 1" UNION |
| 7 | 1" GROMMET |
| 50 FT. | 1" PVC FLEX LINE |
| 1 | GAST BLOWER R2103 |
| 1 | BLOWER HOUSING |
| 1 | BLOWER FILTER SCREEN ASSEMBLY |
| 2 | 1" MALE ADAPTOR |
| 6 | 1" PVC PIPE NIPPLE - 2" LONG |
| 1 | MANIFOLD VALVE BOX |



AQUA TEST
INCORPORATED
1-800-221-3159

| | |
|-----------|-----------|
| DESIGNER | |
| PROJECT | |
| ADDRESS | |
| TITLE | 3-CBP |
| NO. SCALE | |
| DATE | NOV. 2004 |
| SHEET | 1 OF 2 |



3-CBP
AquaTest NIBBLER® CBP COMPONENTS 1-800-221-3159

NOTE:
 ALL NIBBLER® CBP COMPONENTS SHALL BE OBTAINED
 AS A PACKAGE FROM AquaTest Inc. 1-800-221-3159

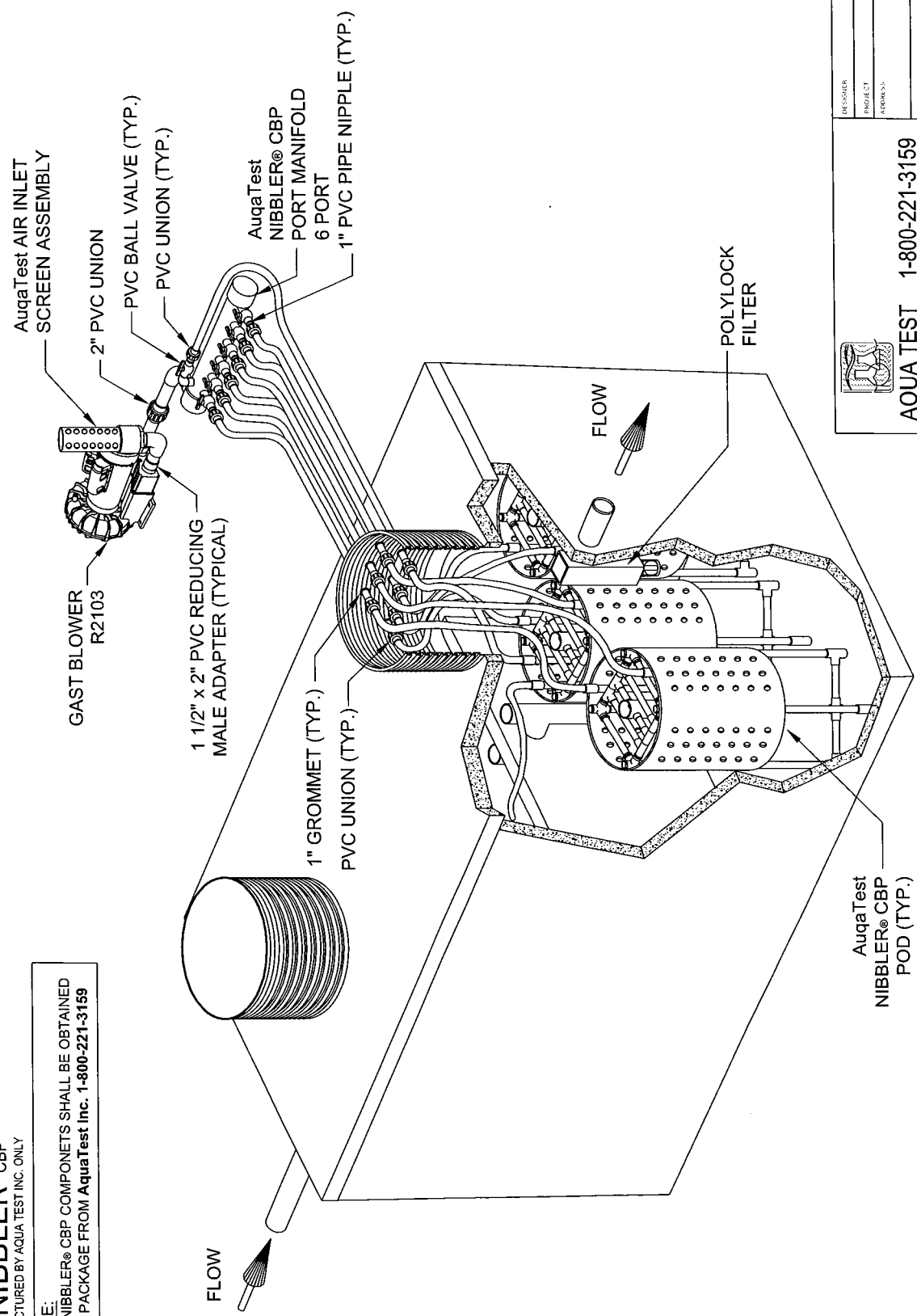

| | | | |
|--|-------------------------------|-----------------------------------|----------------------------------|
|  AQUA TEST INCORPORATED | | 1-800-221-3159 | |
| <small>REVISIONS</small> PRODUCT ADDRESS | <small>TITLE</small> 3-CBP | <small>REV. SCALE</small> DATE | <small>REV. 2008</small> DATE |
| | | <small>SHEET</small> 2 OF 2 | |

Copyright AquaTest Incorporated - All Rights Reserved



2-CBP AquaTest NIBBLER® CBP COMPONENTS 1-800-221-3159

NOTE:
ALL NIBBLER® CBP COMPONENTS SHALL BE OBTAINED
AS A PACKAGE FROM AquaTest Inc. 1-800-221-3159

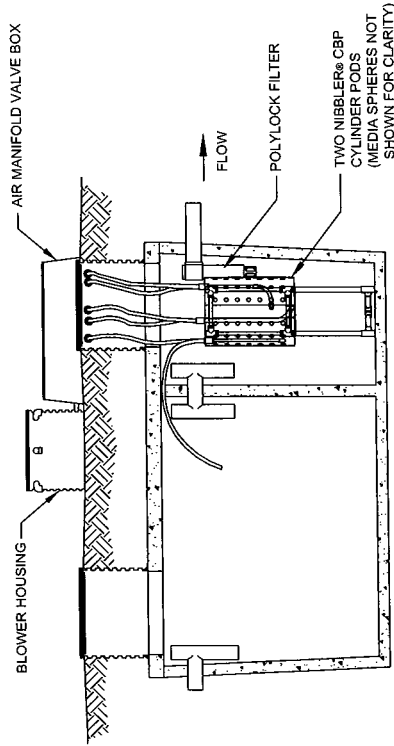
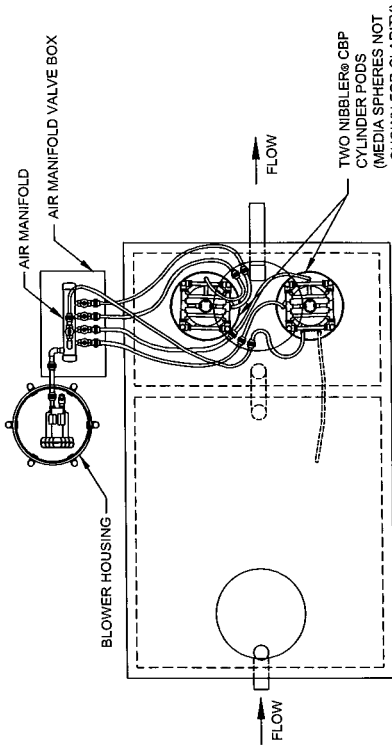

2-CBP
(MINIMUM 1000 GAL. EXISTING TANK)

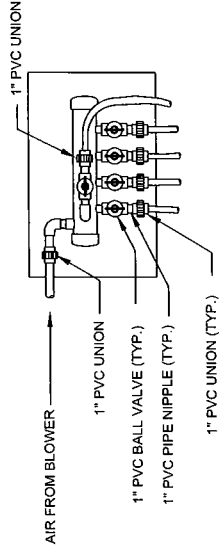

| AquaTest NIBBLER® CBP COMPONENTS | |
|----------------------------------|--------------------------------------|
| QTY. | DESCRIPTION |
| 2 | AquaTest NIBBLER® CBP UNIT |
| 2 | SET NIBBLER® CBP LEGS |
| 2 | NIBBLER® CBP STABILIZER |
| 1 | NIBBLER® CBP PORT MANIFOLD - 4 PORTS |
| 10 | 1" UNION |
| 5 | 1" GROMMET |
| 30 FT. | 1" PVC FLEX LINE |
| 1 | GAST BLOWER R1110 |
| 1 | BLOWER HOUSING |
| 1 | BLOWER FILTER SCREEN ASSEMBLY |
| 2 | 1" MALE ADAPTOR |
| 4 | 1" PVC PIPE NIPPLE - 2" LONG |
| 1 | MANIFOLD VALVE BOX |



AQUA TEST
INCORPORATED
1-800-221-3159

| | |
|-----------|-----------|
| DESIGNER | |
| PROJECT | |
| ADDRESS | |
| TITLE | 2-CBP |
| NO. SCALE | DATE |
| | REV. 2008 |
| | SHEET |
| | 1 OF 2 |



1-CBP AquaTest NIBBLER® CBP COMPONENTS 1-800-221-3159

NOTE:
ALL NIBBLER® CBP COMPONENTS SHALL BE OBTAINED
AS A PACKAGE FROM AquaTest Inc. 1-800-221-3159

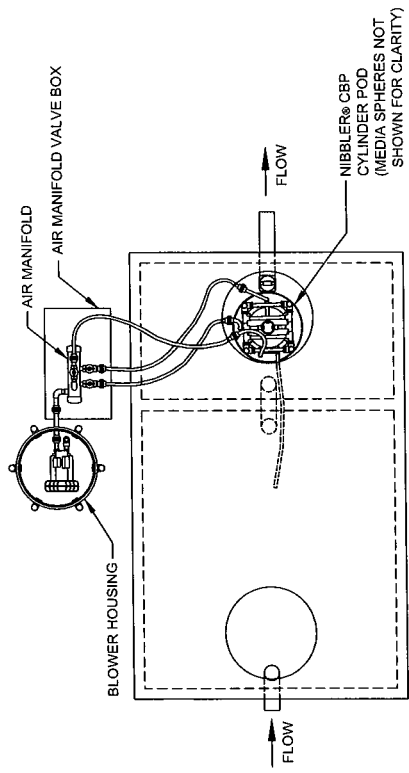

PLAN VIEW
NTS

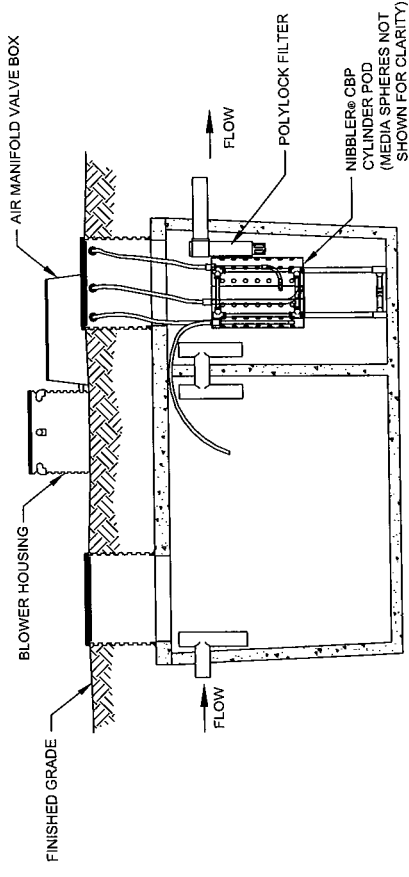

ELEVATION
NTS

1-CBP
(MINIMUM 1000 GAL. EXISTING TANK)

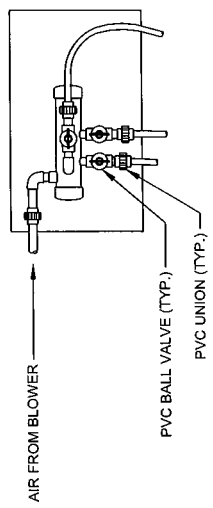

AIR MANIFOLD VALVE BOX DETAIL
NTS

| QTY. | DESCRIPTION |
|--------|--------------------------------------|
| 1 | AquaTest NIBBLER® CBP UNIT |
| 1 | SET NIBBLER® CBP LEGS |
| 1 | NIBBLER® CBP STABILIZER |
| 1 | NIBBLER® CBP PORT MANIFOLD - 2 PORTS |
| 3 | 1" UNION |
| 3 | 1" GROMMET |
| 20 FT. | 1" PVC FLEX LINE |
| 1 | GAST BLOWER R1102 |
| 1 | BLOWER HOUSING |
| 1 | BLOWER FILTER SCREEN |
| 2 | 1" MALE ADAPTOR |
| 2 | 1" PVC PIPE NIPPLE - 2" LONG |
| 1 | MANIFOLD VALVE BOX |



AQUA TEST
INCORPORATED
1-800-221-3159

| | | |
|----------|-----------|-----------|
| DESIGNER | PROJECT | ADDRESS |
| DATE | NO. SCALE | NOV. 2008 |
| SHEET | | 1 OF 2 |



MANUFACTURED BY AQUA TEST, INC. ONLY

NOTE:
ALL NIBBLER® CBP COMPONENTS SHALL BE OBTAINED
AS A PACKAGE FROM AquaTest Inc. 1-800-221-3159

1-CBP
AquaTest NIBBLER® CBP COMPONENTS 1-800-221-3159

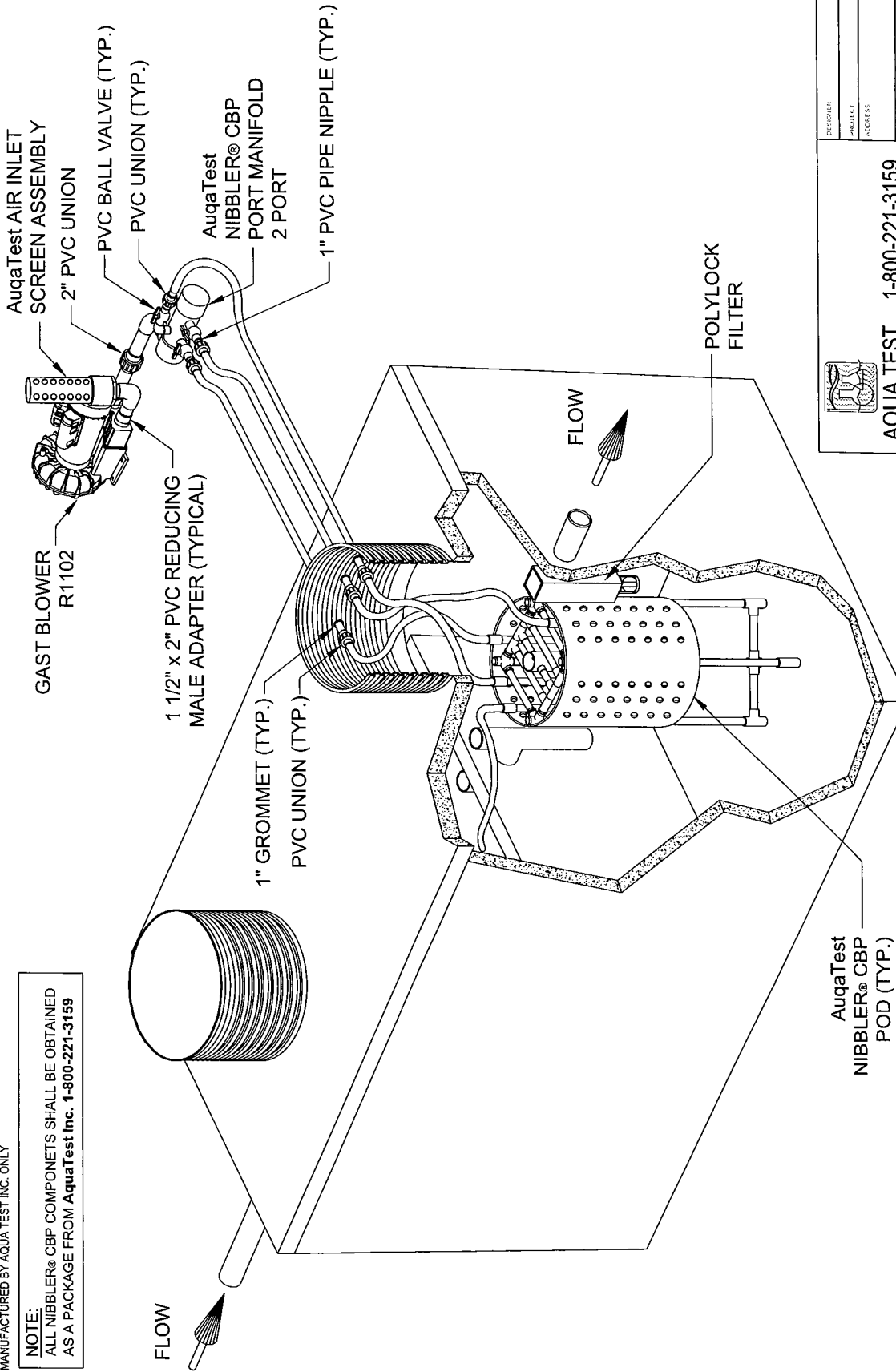

AQUA TEST
INCORPORATED
1-800-221-3159

Copyright AquaTest Incorporated - All Rights Reserved

| | |
|-----------|----------|
| DESIGNER | |
| PROJECT | |
| ADDRESS | |
| TITLE | 1-CBP |
| NO. SCALE | DATE |
| | NOV 2008 |
| | SHEET |
| | 2 OF 2 |

Appendix B

Blower Specifications

Blower System Design Tips

In order to utilize your regenerative blower most efficiently, proper system design is essential. The most important thing to recognize is that by utilizing large diameter plumbing, friction losses in plumbing can be greatly reduced. Here are some guidelines to use when setting up your blower system:

1. The plumbing should at least be the same size as the blower port or ideally one size larger (example - blower has ports that are 1-1/2" NPT, plumbing should be 2" NPT). The plumbing should remain this size until it has reached the location of the work area.
2. Plumbing for Separate Drive Blowers operating above 3500 RPM should be at least one pipe size larger than the blower ports.
3. Elbows create additional friction which causes pressure loss and back pressure. Plumbing at least one pipe size larger than the blower pipe ports minimizes the friction loss they create.
4. The pressure/vacuum relief valve should be installed in a "T" which is at least one pipe size larger than that of the exhaust of the blower. To properly protect a large horsepower blower, set the relief value to limit the blowers duty to 5 in. H₂O below its continuous duty rating.
5. Operating the blowers at high altitude decreases their maximum pressure or vacuum duty rating. If this is a consideration, review the information on Fan Laws in the Application Engineering section of this catalog.
6. The exhaust air temperature of the blowers increases with increasing duty. At duties over 70 in. H₂O it is too hot for most plastic pipe. Metal pipe must be considered. To prevent danger of burns, access to these pipes should be limited, guarded or marked "Danger Hot."

Performance Data

The performance data shown in this catalog was determined under the following conditions:

- Line voltage @ 60 Hz. 230V or 460V for three-phase units. 115V or 230V for single-phase units.
- Line voltage @ 50Hz. 220V for three-phase or single-phase units.
- Units in a temperature stable condition.
- Delivery measurements made with output port throttled.
- Suction measurements made with input port throttled.
- Test Conditions: Inlet air density at 0.075 lbs. per cu.ft. [20°C (68°F), 29.92 in. Hg (14.7 PSIA)].
- Normal performance variations on the resistance curve within ± 10% of supplied data can be expected.

Pictorial and dimensional data is subject to change without notice.

The information presented in this catalog is based on technical data and test results of nominal units. It is believed to be accurate and is offered as an aid in the selection of Gast products. It is the user's responsibility to determine suitability of the product for intended use and the user assumes all risk and liability whatsoever in connection therewith.

Gast can also provide CE compliant blowers with BSP threads, as well as customized blowers for specific applications. Consult a Gast Representative/Distributor for more information.

Environmental and application conditions may affect advertised life.

Warning:

Models Without Explosion-Proof Motors Should Not Pump Combustible Gases or Be Used In Combustible Ambients



Performance Table

| MODEL/ SERIES | POWER RATING @ 60 Hz | | FREE AIR FLOW | | | | MAXIMUM PRESSURE | | | | MAXIMUM VACUUM | | | |
|---|-------------------------|---------------|---------------|-------------|-------------|-------------|--------------------|------------|-------------|-------------|--------------------|-----------|-------------|-------------|
| | hp | kW | cfm | | m³/h | | " H ₂ O | | mbar | | " H ₂ O | | mbar | |
| | | | 50 Hz | 60 Hz | 50 Hz | 60 Hz | 50 Hz | 60 Hz | 50 Hz | 60 Hz | 50 Hz | 60 Hz | 50 Hz | 60 Hz |
| Standard Motor Mounted Models | | | | | | | | | | | | | | |
| R1* | 1/8 | 0,09 | 23 | 27 | 39 | 46 | 21 | 28.5 | 52 | 71 | 20 | 26.5 | 50 | 66 |
| R2* | 1/8, 1/2 | 0,25, 0,37 | 33 | 42 | 56 | 71 | 30 | 39 | 75 | 97 | 25 | 35 | 62 | 87 |
| R3* | 1/2 | 0,37 | 43-44 | 52-53 | 73-75 | 88-90 | 31-40 | 43-55 | 77-100 | 107-137 | 28-35 | 40-50 | 70-87 | 100-125 |
| R4* | 1 | 0,75 | 75 | 92 | 127 | 156 | 38 | 52 | 95 | 130 | 35 | 48 | 87 | 120 |
| R4P* | 1 1/2 | 1,1 | 110 | 127 | 187 | 216 | 50 | 65 | 125 | 162 | 45 | 60 | 112 | 149 |
| R5* | 2 1/2 | 1,86 | 133 | 160 | 226 | 272 | 50 | 65 | 125 | 162 | 47 | 60 | 117 | 149 |
| R6* | 2 1/2- 5 | 1,86- 3,73 | 180 | 207- 215 | 306 | 352- 365 | 40- 78 | 45- 105 | 100- 194 | 112- 262 | 50- 70 | 55- 88 | 125- 194 | 137- 262 |
| R6P* | 3 1/2- 5 1/2 | 2,6- 4,1 | 225- 245 | 265- 290 | 382- 416 | 450- 493 | 50- 85 | 30- 110 | 125- 212 | 75- 274 | 50- 85 | 35- 90 | 126- 212 | 87- 224 |
| R6PP* | 11 | 8,2 | 420 | 520 | 714 | 884 | 75 | 95 | 187 | 237 | 65 | 80 | 162 | 199 |
| R7* | 10 | 7,46 | 350 | 420 | 595 | 714 | 115 | 125 | 286 | 311 | 90 | 110 | 224 | 274 |
| R7P* | 18 | 13,4 | 666 | 795 | 1132 | 1351 | 90 | 105 | 284 | 262 | 85 | 95 | 212 | 237 |
| R9* | 15 | 11,3 | 585 | 680 | 994 | 1155 | 125 | 125 | 311 | 311 | 105 | 115 | 262 | 286 |
| R9P* | 30 | 22,4 | 1140 | 1350 | 1937 | 2294 | 110 | 125 | 274 | 311 | 100 | 110 | 249 | 274 |
| High Pressure Motor Mounted Models | | | | | | | | | | | | | | |
| R4H* | 6 | 4,5 | 107 | 128 | 182 | 217 | 284 | 284 | 707 | 707 | 183 | 183 | 456 | 456 |
| R6PS* | 11 | 8,2 | 230 | 280 | 391 | 476 | 145 | 170 | 361 | 423 | 110 | 130 | 274 | 324 |
| R7S* | 18 | 13,4 | 350 | 420 | 595 | 714 | 170 | 200 | 423 | 498 | 130 | 150 | 324 | 374 |
| R9S* | 30 | 22,4 | 585 | 660 | 994 | 1121 | 208 | 222 | 518 | 553 | 142 | 149 | 354 | 371 |
| Explosion Proof Motor Models | | | | | | | | | | | | | | |
| R3105N-50 | 1/2 | 0,37 | 44 | 53 | 75 | 90 | 31 | 43 | 77 | 107 | 28 | 40 | 70 | 100 |
| R4110N-50 | 1 | 0,75 | 74 | 92 | 126 | 156 | 38 | 51 | 95 | 127 | 35 | 48 | 87 | 120 |
| R4310P-50 | 1 | 0,75 | 74 | 92 | 126 | 156 | 38 | 51 | 95 | 127 | 35 | 48 | 87 | 120 |
| R4P115N-50 | 1 1/2 | 1,1 | 112 | 133 | 190 | 226 | 45 | 65 | 112 | 162 | 40 | 60 | 100 | 149 |
| R5125Q-50 | 2 | 1,5 | — | 160 | — | 272 | — | 55 | — | 137 | — | 60 | — | 149 |
| R5325R-50 | 2 | 1,5 | 133 | 160 | 226 | 272 | 50 | 65 | 125 | 162 | 47 | 65 | 117 | 162 |
| R6130Q-50 | 3 | 2,2 | 180 | 215 | 306 | 365 | 75 | 60 | 187 | 149 | 65 | 70 | 162 | 174 |
| R6340R-50 | 4 | 3,0 | 180 | 215 | 306 | 365 | 75 | 100 | 187 | 249 | 65 | 80 | 162 | 199 |
| R6P155Q-50 | 5 1/2 | 4,1 | 235 | 280 | 399 | 476 | 80 | 95 | 199 | 237 | 65 | 85 | 162 | 212 |
| R6P355R-50 | 6 | 4,5 | 232 | 280 | 394 | 476 | 80 | 100 | 199 | 249 | 65 | 85 | 162 | 212 |
| R7100R-50 | 10 | 7,5 | 350 | 425 | 595 | 722 | 90 | 100 | 224 | 249 | 85 | 110 | 212 | 274 |
| Separate Drive Models | | | | | | | | | | | | | | |
| SDR4 | 4 | 3,0 | 147 | | 250 | | 110 | | 274 | | 90 | | 224 | |
| SDR5 | 10 | 7,5 | 240 | | 408 | | 152 | | 379 | | 120 | | 299 | |
| SDR6 | 15 | 11,2 | 300 | | 510 | | 155 | | 386 | | 135 | | 336 | |

*Models equipped with UL and CSA certified motors. (except R1102K (12v DC))

Performance Curves - Low Range for Pressure/Vacuum

Motor mounted series R1, R2, R3, R4, R4P, R5

Performance at 60 Hz

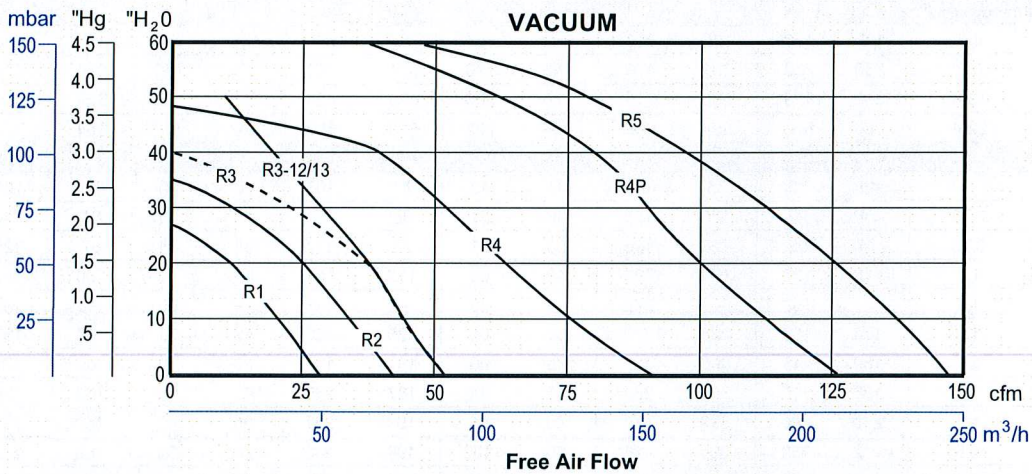
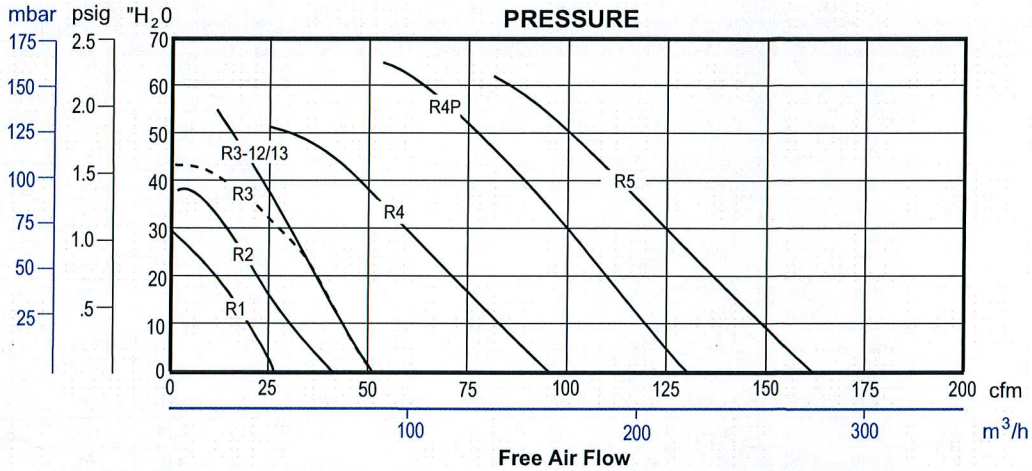

Gast advertises blower performance in Free Air Flow, or air subjected to only atmospheric pressure. (See above curves)

Some blower manufacturers advertise vacuum performance in CFM Inlet Air - measurement of the suction of air at a specific temperature at the inlet port and a specific discharge pressure at the exhaust port, which can be perceived as enhanced performance over Free Air Flow rated blowers. Therefore, we are also providing the following vacuum performance for Gast blowers in CFM Inlet Air for comparison to other blower manufacturer's advertising.

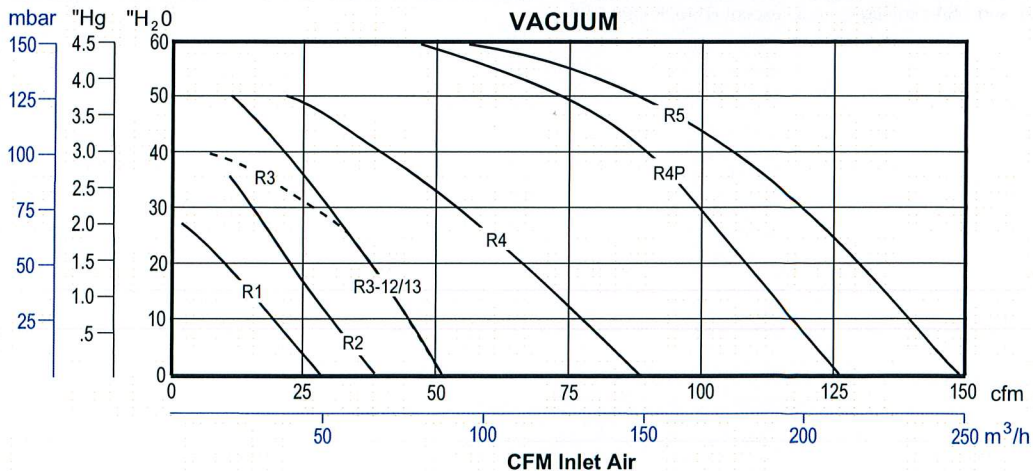

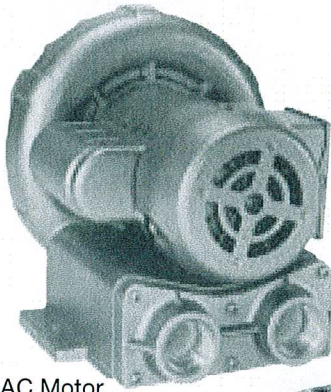

AC Motor

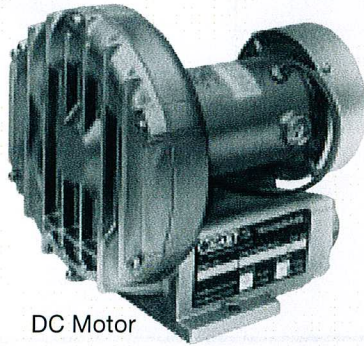

DC Motor

R1 SERIES

MODELS R1102, R1102C, R1102K

MAX. PRESSURE – 28.5"H₂O (60 Hz), 21"H₂O (50 Hz)

MAX. VACUUM – 26.5"H₂O (60 Hz), 20"H₂O (50 Hz)

MAX. AIR FLOW – 27 CFM (60 Hz), 23 CFM (50 Hz)

PRODUCT FEATURES

- Rugged construction, low maintenance
- Oilless operation
- UL and CSA approved TEFC motors with permanently sealed ball bearings
- Automatic restart thermal protection on single phase AC motors
- Estimated 3,000 hour brush life on 12 volt DC motor
- Can be operated with no air flow through unit.
- Aluminum blower housing, impeller and cover
- Can be mounted in any plane
- Inlet and outlet have internal muffling

RECOMMENDED ACCESSORIES

- Pressure gauge AJ496
- Inlet Filter AJ126B (pressure)
- Vacuum gauge AJ497
- Inline filter AJ151A (vacuum)
- Muffler AJ121B
- K899 foam replacement kit for R1102

Product Dimensions (in. mm)

MODELS R1102,
R1102C, R1102K,

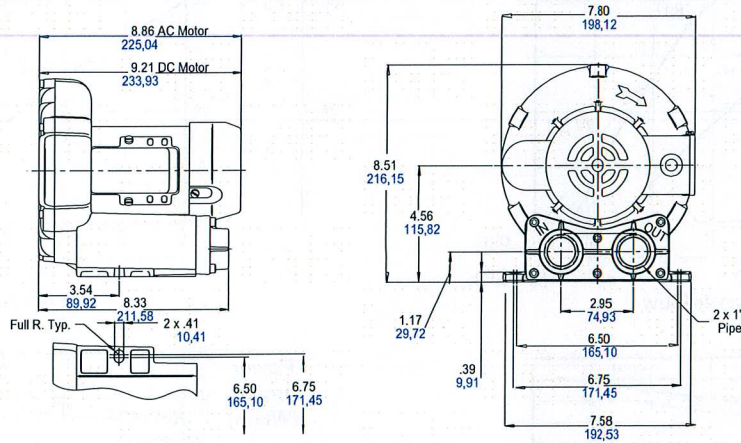



Product Specifications

| MODEL NUMBER | | R1102 | R1102C | R1102K |
|-------------------------------|-------|---------------|-----------|--------------|
| Motor Enclosure | | TEFC | TEFC | TEFC |
| HP/kW | 60 Hz | .125/0,09 | .125/0,09 | .125/0,09 |
| | 50 Hz | .10/0,07 | - | - |
| Voltage | 60 Hz | 115/208-230-1 | 115-1 | 12V DC |
| | 50 Hz | 110/220-240-1 | - | - |
| Amps | 60 Hz | 2.0/1.1-1.0 | 1.8 | 19 @ 12V DC |
| | 50 Hz | 2.0/1.1-1.0 | - | - |
| Starting Amps | 60 Hz | 8.5 @ 115V | 9.7 | 145 @ 12V DC |
| | 50 Hz | 8.6 @ 220V | - | - |
| Insulation Class | | B | B | H |
| Recommended NEMA Starter Size | | 00/00 | 00 | - |
| Net Weight (lbs/kg) | | 16/7,3 | 16/7,3 | 16/7,3 |

Product Performance

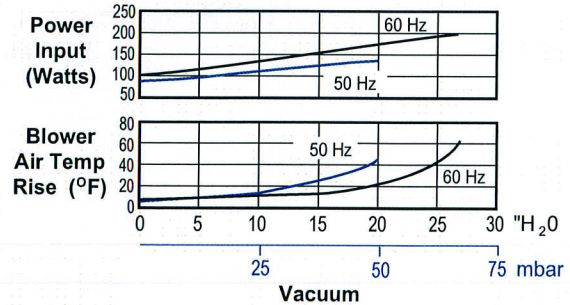
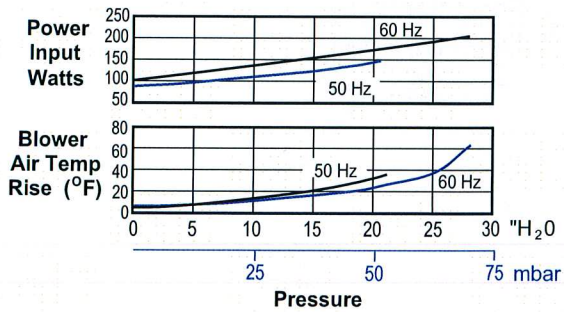
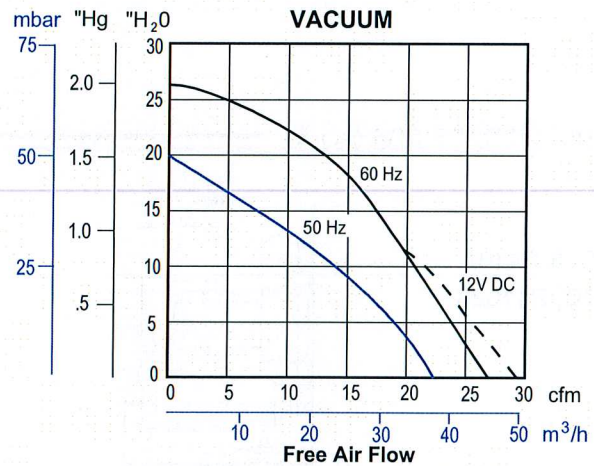
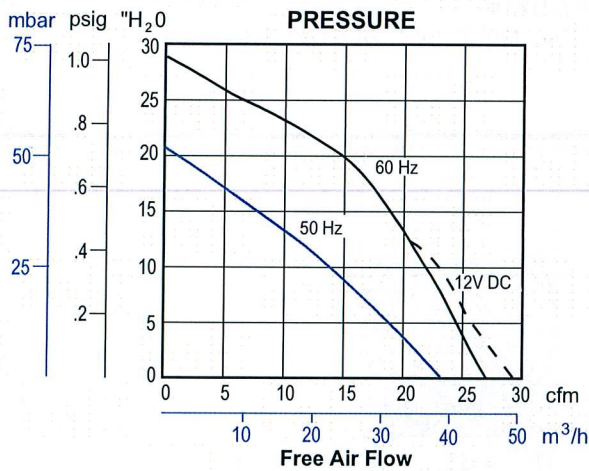

Appendix C

Field Checklist Form

MONITORING CHECKLIST

Customer Name

Address

NIBBLER® CBP

DATE _____ TIME _____ INSPECTION ID _____

DATE LAST CHECKED _____ DAYS THIS PERIOD _____ INSPECTED BY _____

| | | | | | |
|---------|---|-----------|---|------------------|---|
| ROUTINE | Δ | | | | |
| PROBLEM | Δ | CORRECTED | Δ | NEEDS CORRECTION | Δ |
| | | NEEDS F/U | Δ | EMERGENCY | Δ |
| | | NO F/U | Δ | NOT URGENT | Δ |

THIS FORM SHALL BE COMPLETED BY THE SYSTEM MANAGER AND SUBMITTED TO THE OWNER & MANUFACTURER UPON COMPLETION OF EACH INSPECTION.

BLOWER FAN:

| | | | | |
|-----------------------|-------|-------|-------|-----------------------------|
| FAN | _____ | OK | _____ | MALFUNCTION |
| FAN AIR INTAKE FILTER | _____ | CLEAN | _____ | NEEDED CLEANING/WAS CLEANED |

NIBBLER CBP. RECIRC. COLLECTION SPOON:

OPENING DISTANCE FROM CENTER DRAFT TUBE: _____ " CORRECT: YES / NO
 IF NO, CHANGED TO: _____ "

| | | | |
|-------------------------|---------------|--------------|-------|
| SLUDGE LEVELS IN TANKS: | ACCUM. SLUDGE | FLOATING MAT | COLOR |
|-------------------------|---------------|--------------|-------|

SEPTIC TANK:
 1ST COMP. _____ "
 2ND COMP. _____ "

Vent Cap Installed in the _____ Outlet or _____ Inlet

PH _____ D.O. _____ Temp _____ C°

EVIDENCE OF EFFLUENT SURFACING: YES / NO _____

OBSERVATION OF LIQUID IN DRAINFIELD TEST PORTS: #1 _____ " #2 _____ "

OBSERVATIONS: _____

Appendix D

Glossary

GLOSSARY OF TERMS

Advanced Treatment Unit - A Sand Filter, Recirculating Gravel Filter, or other device which is designed to reduce waste levels to less than 30 mg/L (BOD₅, TSS & O&G) Many of these units will reduce waste strength levels to less than 10mg/L.

Aerobic - (1) A condition where free oxygen or dissolved oxygen is present. (2) Requiring or not destroyed by free oxygen. Generally referred to organisms, which use free oxygen for respiration.

Air Lift Pump - A pump that lifts water using air. In NIBBLER Jr[®] systems an air lift pump is typically a pipe section with a smaller air tube in the center. The air tube delivers a large volume of air below the liquid level inside the larger pipe, which displaces the liquid in the large pipe and forces it out the top,

Anaerobic - (1) A condition where free oxygen or dissolved oxygen is not present. (2) Requiring or not destroyed by the absence of free oxygen. Generally referring to organisms, which do not require free oxygen for respiration.

ATU - Aerobic Treatment Unit - Typically a proprietary device which uses air to treat wastewater.

Blackwater - Generally refers to flows from bathroom fixtures, i.e. toilets, sinks & urinals.

Baffle - Typically a plastic or concrete device mounted at the inlet or outlet of a tank wall intended to collect/discharge water from/to the clear zone in the tank.

BOD₅ - Biochemical Oxygen Demand over a five-day test period. Generally refers to the amount of oxygen required by bacteria to stabilize organic matter under aerobic conditions It is determined entirely by the availability of the material in the wastewater be used as food and by the amount of oxygen utilized by the microorganisms during oxidation.

Bulking -As a sludge blanket matures it will produce gasses. As the gasses release they produce a zone of poorly settled flocculated material. This process is referred to as bulking.

Clear Zone - Typically the middle zone in the tank. Represents the clearest liquid in the tank.

Drainfield - Generally refers to a subsurface method or wastewater disposal.

Drawdown - Refers to the process of pumping a tank down a specific volume over a measured time. This information is then used to calculate a pump discharge rate (in GPM). A drawdown should be performed with the tank half full and the system components hooked up, as they would be for normal system operation.

Facultative - (1) Able to function both in the presence or absence of free oxygen. Generally refers to organisms, which can use free oxygen or bound oxygen for respiration.

Greywater - Greywater represents the flows from sources other than bathroom waste. Typically refers to waste flow from the kitchen and laundry.

GPD - Gallons per day.

GPM - Gallons per minute.

High Strength Waste - Generally refers to wastewater flows which have a $BOD_5 > 150$ mg/L, $TSS > 80$ mg/L and $O\&G > 20$ mg/L.

Media - Typically a plastic material used as a surface area for the growth of large microorganism population. May be trickle media (exposed to air), or submerged media (below the liquid level).

O&G - Oil and grease.

pH - An expression of the intensity of the alkaline or acidic strength of the water.

Septic Tank - Tank designed to retain solids (floatable and sinkable). Generally designed to have a 1.5 to 2 days detention time based on design flows.

TSS - Total Suspended Solids measured in mg/L or parts per million (PPM).

Dissolved Oxygen

The Dissolved Oxygen (DO) level in wastewater is an important aspect of aerobic treatment and a good tool for troubleshooting. However, DO is a very dynamic parameter and can vary considerably from system to system and from component to component. For each system you work on, you will develop a normal set of operating parameters (including DO). The following general statements are related to DO and the NIBBLER[®] CBP system:

- DO measurement is affected by; temperature, barometric pressure (altitude), and salinity. You must input the local altitude into the meter before you measure the DO in the wastewater.
- The DO in the various NIBBLER[®] CBP components can be affected by; the waste strength of the influent, the aeration, the DO in the source water, and ground water infiltration.
- In a grease trap or septic tank the DO is generally between 0.0 and 0.5 mg/L and almost always less than 1 mg/L. However, the DO in a grease trap or septic tank with a Nibbler Jr[®] installed in it will be higher than this and will be dependent of the waste strength, flow volume, and the recirculation ratio,
- The DO in a NIBBLER[®] CBP unit varies with depth, waste strength, and maturity of the organism population (food to micro-organism ratio). The DO in the NIBBLER Jr[®] unit generally ranges between 1 and 3 mg/L (not in the draft tube, and in mature system older than 2 months). In a properly operating NIBBLER[®] CBP system you will generally find that as you increase in depth the DO decreases. The DO in the sludge at the bottom of the tank may

approach zero. The DO in the NIBBLER[®] CBP unit is directly affected by the waste strength and re-circulation ratio.

High DO: It is possible for a NIBBLER[®] CBP unit to appear to have a very high DO (8-10 mg/l) and have very poor treatment occurring in the unit. If a vent line is obstructed the NIBBLER[®] CBP unit may receive poor aeration when the lids are closed. When the lid is opened, the unit appears to have excellent aeration. Since the unit has been operating without good aeration, there will be a small population of aerobic organisms. Therefore, the oxygen level will rise to near saturation levels without a hungry population of organism there to stabilize it. In addition, the effluent quality will not be as good and there is likely to be an odor present.

As previously noted the DO in different NIBBLER[®] CBP systems can vary. With each system you will develop a set of normal operating parameters including DO. Keeping a good record of the systems performance will help make the long term monitoring and maintenance easier.