



CLEARSTREAM®

WASTEWATER SYSTEMS, INC.

P.O. Box 7568 Beaumont, Texas 77726 (409) 755-1500

ONSITE WASTEWATER EFFLUENT UV DISINFECTION DEVICE MODEL 120 UV UNIT PART #P8888

I. CLEARSTREAM MODEL 120 UV UNIT

1. Clearstream manufactures a UV disinfection unit for wastewater treatment applications. UV is a proven method to protect the health and environment from pathogens in wastewater because:
 - It is extremely effective at eradicating viruses and bacteria
 - It is very energy efficient
2. Clearstream's 120 UV Unit has been tested numerous times by third party testing sites in the effluent stream of Clearstream's ATU's.
3. An optional benefit of Clearstream's 120 UV Unit is when used with the RMSYS Monitoring System maintenance personnel can be notified electronically (i.e. cell phone, computer, iPad) of UV system failure.

II. INSTALLATION INSTRUCTIONS

1. First, unpack the unit and check for any damage in shipping. There are seven (7) sub-assemblies that comprise the UV system, which are:
 - a. Disinfection chamber – 3" ABS with 4" inlet and 4" outlet hubs.
 - b. Disinfection subassembly – bulb support frame packed inside the disinfection chamber.
 - c. PVC handle to remove frame.
 - d. UV lamp – packed inside the PVC handle.
 - e. Riser pipe 4" ABS with a 3/4" PVC nipple at one end. The PVC handle with UV lamp are packed inside.
 - f. Electrical subassembly – junction box with pre-wired alarm board, electronic ballast and UV lamp power cable.
 - g. Two (2) 4" Schedule 40 ABS pipe couplings.

Please NOTE: Inspect the unit upon receipt and report any damage to the shipper (i.e. UPS, FedEx, etc.) Clearstream is not responsible for damage in shipment. If a part is defective, then see Clearstream Warranty.

III. CONTRACTOR SUPPLIED MATERIAL LIST:

1. ABS cement (also a multipurpose cement if you will be bonding to PVC pipe)
2. Silicone sealant
3. Teflon tape
4. Isopropyl alcohol
5. Power and control wiring (a schematic wiring diagram is included with this package)

IV. INSTALLATION METHODS:

1. UV assembly in the ground – couple the 4" inlet side of the 120 UV UNIT to the 4" pipe exiting the Clearstream Treatment System, then couple the 4" outlet side to the 4" pipe going to the method of treated effluent disposal.
2. UV assembly in the pump tank – couple the 4" inlet side of the 120 UV UNIT to the 4" inlet pipe entering the pump tank.

Please NOTE: The electrical junction box if above grade should always be protected from mowing machines, etc., and from flooding if installed in a pump tank or meter vault.

V. MAINTENANCE AND SERVICE

1. The Clearstream UV Disinfectant Device Unit is designed to provide long service life. It is recommended that the UV lamp be replaced every one (1) to two (2) years to insure proper disinfection. To replace the lamp:
 - a. Power off the dedicated UV circuit breaker located in the system electrical panel that supplies power to the UV System.
 - b. For personnel protection put on gloves and eye protection before removing the electrical junction box and ballast from the UV disinfection chamber and carefully set it aside.
 - c. Using the power line connected to the UV lamp as a lifting device, lift the lamp up out of the disinfection assembly.
 - d. Disconnect the four (4) pin connector attaching the power line to the UV lamp.
 - e. Connect the new lamp to the four (4) pin connector and again using the power line as a lowering device completely lower the new lamp into the UV subassembly.
 - f. Ensure that the remaining power line stored inside the 4" riser pipe.
 - g. Then insert the plastic section on the back side of the control center enclosure into the top of the 4" riser pipe.
 - h. Power on the dedicated UV circuit breaker located in the system electrical panel. The new bulb should illuminate.
2. It is recommended that the disinfection subassembly be removed and serviced a minimum of once (1) per year to insure proper effluent disinfection. To clean the disinfection subassembly, use a soft sponge and mild detergent then rinse with clean water. For the difficult stains on the lamp use isopropyl alcohol on a soft cloth to remove fingerprints and other attached films.

CLEARSTREAM UV DISINFECTION UNIT

CS PART #P8888

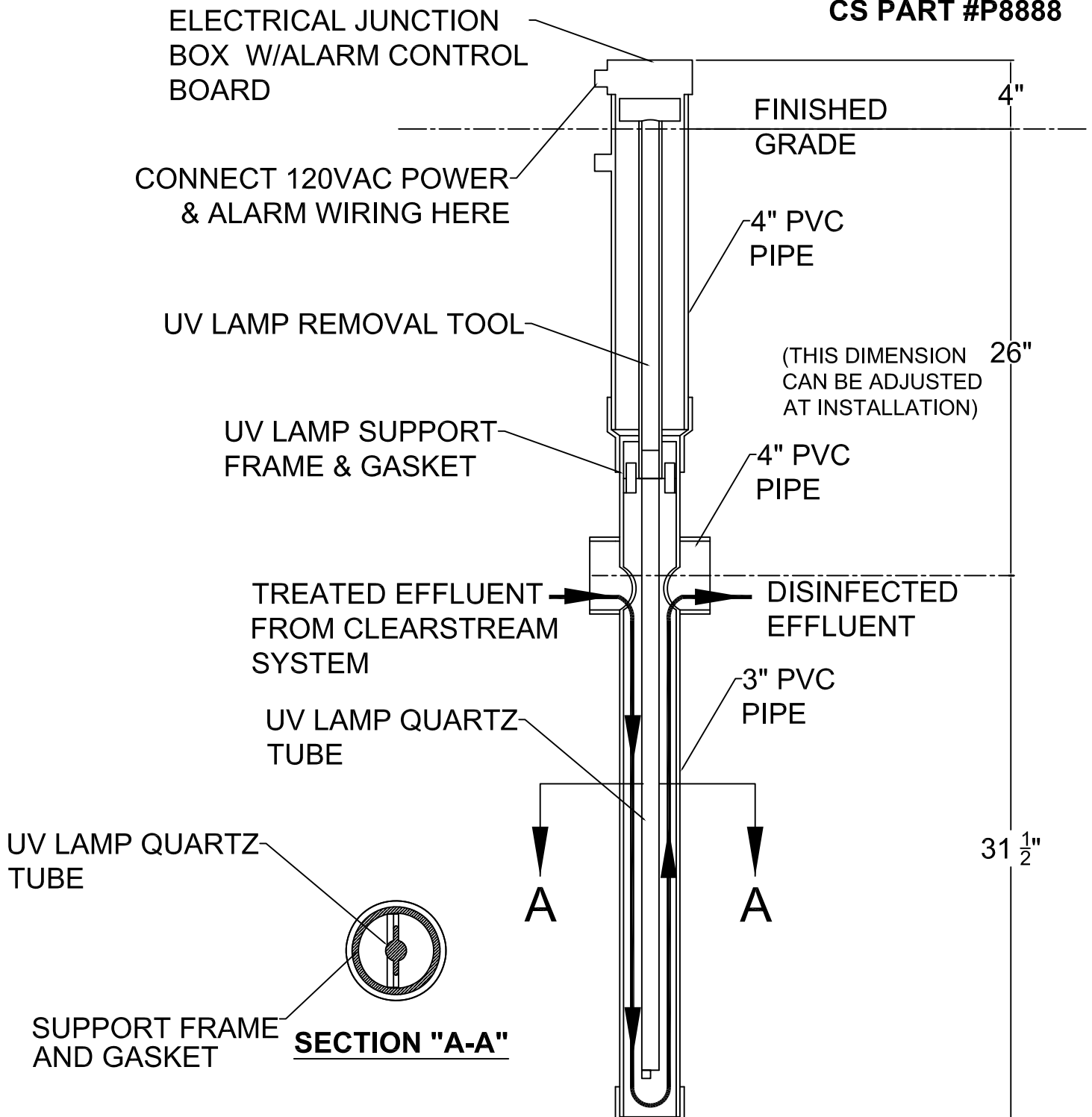

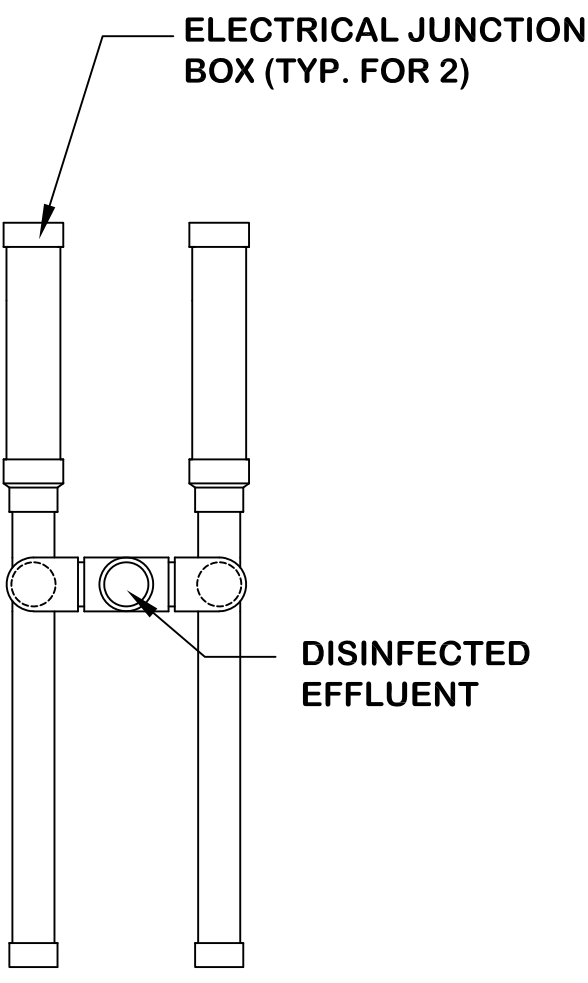
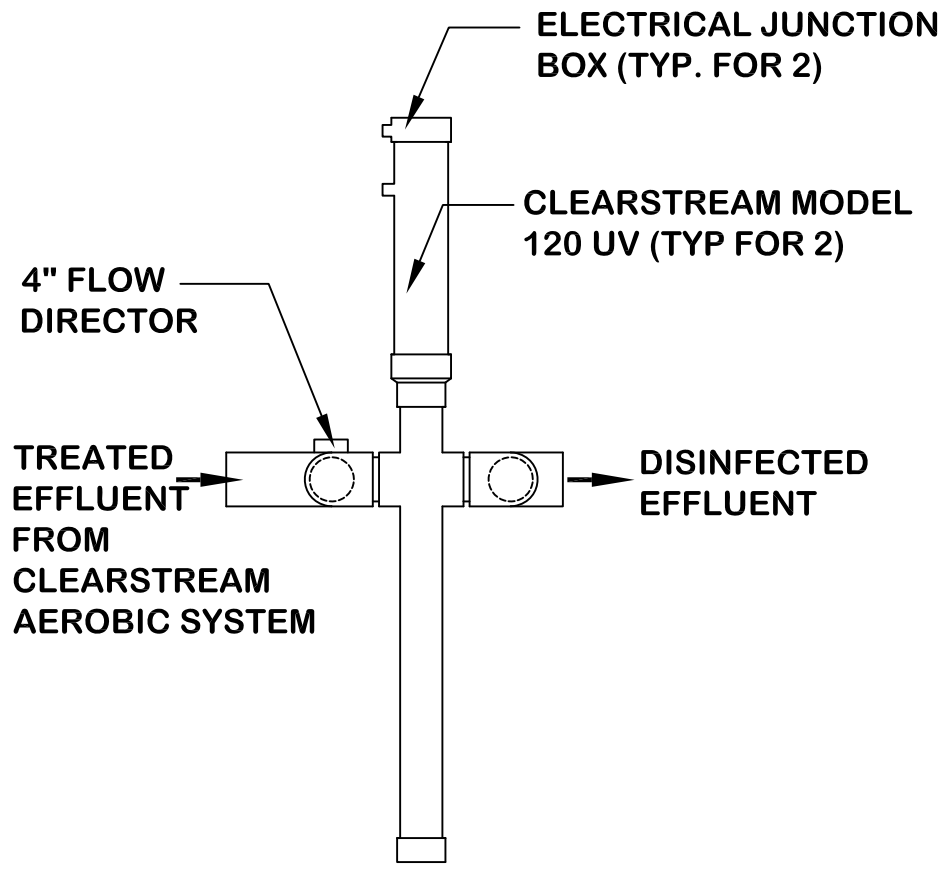
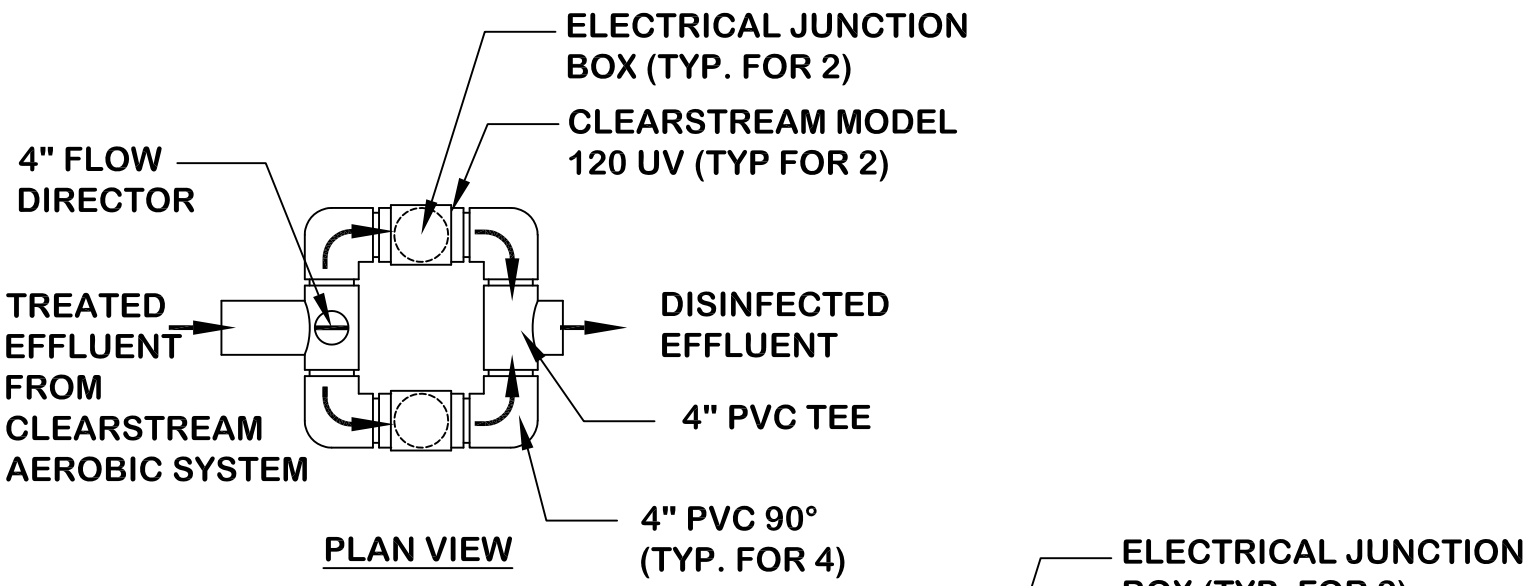

PROPRIETARY AND CONFIDENTIAL

THIS INFORMATION CONTAINED IN THE DRAWING IS THE SOLE PROPERTY OF CLEARSTREAM. ANY REPRODUCTION IN PART OR AS A WHOLE WITHOUT THE WRITTEN PERMISSION OF CLEARSTREAM IS PROHIBITED.

DRAWN BY CWP	DATE 06/13/2016
CHECKED BY JLM	DATE
SCALE: NTS	SHEET 1 OF 1

PARALLEL CHLORINATOR INSTALLATION

DWG. NO. **CS UV-2**

CLEARSTREAM®
WASTEWATER SYSTEMS, INC.
RESIDENTIAL • COMMERCIAL • MARINE

P.O. Box 7568 Beaumont, Texas 77726

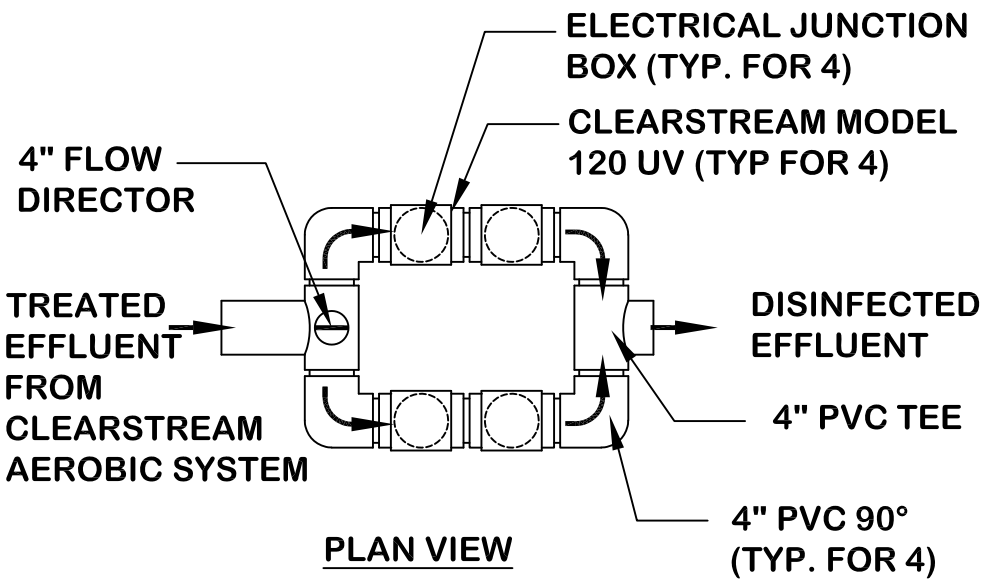

PLAN VIEW

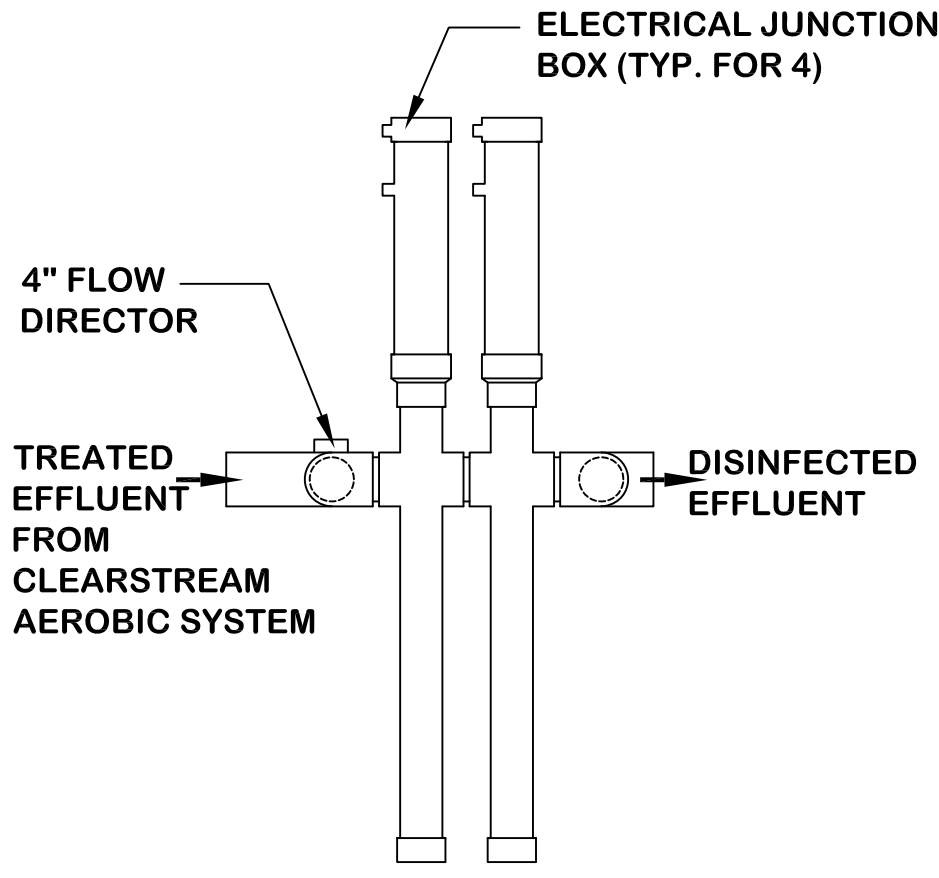

ELEVATION

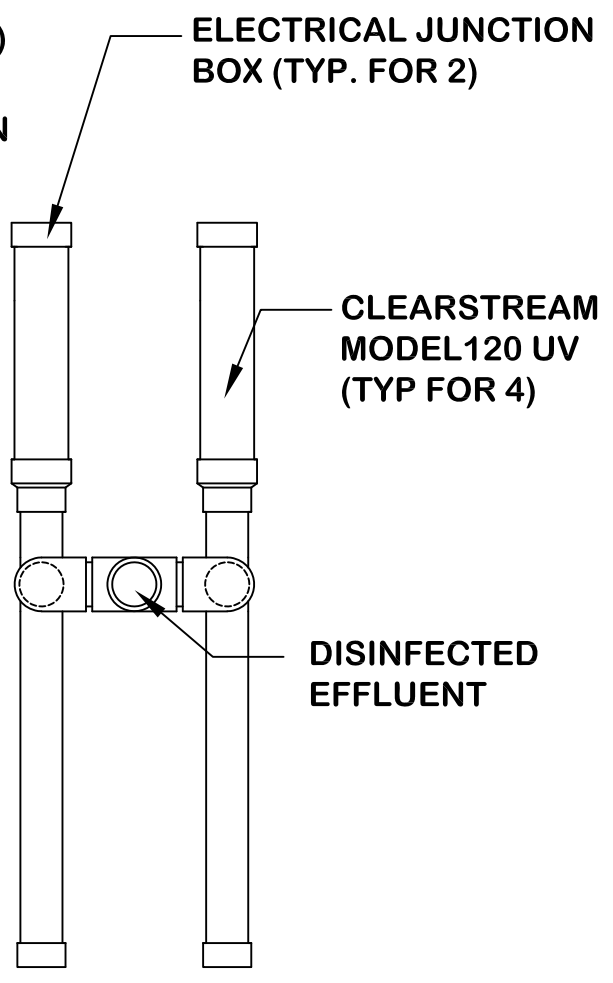

**ELEVATION
SIDE VIEW**

PROPRIETARY AND CONFIDENTIAL

THIS INFORMATION CONTAINED IN THE DRAWING IS THE SOLE PROPERTY OF CLEARSTREAM. ANY REPRODUCTION IN PART OR AS A WHOLE WITHOUT THE WRITTEN PERMISSION OF CLEARSTREAM IS PROHIBITED.

DRAWN BY CWP	DATE 06/13/2016
CHECKED BY JLM	DATE
SCALE: NTS	SHEET 1 OF 1

**PARALLEL/SERIES
CHLORINATOR INSTALLATION**

DWG. NO. **CS UV-3**



P.O. Box 7568 Beaumont, Texas 77726